



US010898346B1

(12) **United States Patent**
Suddaby

(10) **Patent No.:** **US 10,898,346 B1**
(45) **Date of Patent:** **Jan. 26, 2021**

(54) **EXPANDABLE INTERVERTEBRAL FUSION IMPLANT**

(71) Applicant: **Loubert S. Suddaby**, Orchard Park, NY (US)

(72) Inventor: **Loubert S. Suddaby**, Orchard Park, NY (US)

(*) Notice: Subject to any disclaimer, the term of this patent is extended or adjusted under 35 U.S.C. 154(b) by 0 days.

(21) Appl. No.: **16/516,416**

(22) Filed: **Jul. 19, 2019**

(51) **Int. Cl.**
A61F 2/44 (2006.01)
A61F 2/30 (2006.01)

(52) **U.S. Cl.**
CPC *A61F 2/447* (2013.01); *A61F 2002/3055* (2013.01); *A61F 2002/30261* (2013.01); *A61F 2002/30383* (2013.01); *A61F 2002/30405* (2013.01); *A61F 2002/30579* (2013.01); *A61F 2002/30622* (2013.01)

(58) **Field of Classification Search**
None
See application file for complete search history.

(56) **References Cited**

U.S. PATENT DOCUMENTS

5,483,463	A	1/1996	Qin et al.
5,505,732	A	4/1996	Michelson
5,653,761	A	8/1997	Pisharodi
5,653,762	A	8/1997	Pisharodi
5,665,122	A	9/1997	Kambin
5,683,463	A	11/1997	Godefroy et al.
6,126,660	A	10/2000	Dietz

6,159,244	A	12/2000	Suddaby
6,174,334	B1	1/2001	Suddaby
6,325,827	B1	12/2001	Lin
6,332,895	B1	12/2001	Suddaby
7,044,971	B2	5/2006	Suddaby
8,491,659	B2	7/2013	Weiman
8,632,593	B2	1/2014	Suh et al.
8,845,731	B2	9/2014	Weiman
8,845,732	B2	9/2014	Weiman
8,852,279	B2	10/2014	Weiman
9,155,628	B2	10/2015	Glerum et al.
9,833,337	B2	12/2017	Hleihil et al.
9,949,841	B2	4/2018	Glerum et al.
10,010,429	B2	7/2018	Dmuschewski
10,085,849	B2	10/2018	Weiman et al.
10,117,753	B2	11/2018	Suh et al.
10,137,001	B2	11/2018	Weiman
10,143,566	B2	12/2018	Hyder
10,154,912	B2	12/2018	Glerum

(Continued)

FOREIGN PATENT DOCUMENTS

WO WO2009/064787 5/2009

Primary Examiner — Sameh R Boles

(74) *Attorney, Agent, or Firm* — Simpson & Simpson, PLLC; Michael Nicholas Vranjes

(57) **ABSTRACT**

An expandable intervertebral fusion implant capable of being expanded in three dimensions, said implant including an inferior component, including a plate, and a first wedge slidably connected to the plate, the first wedge having a first surface, and a superior component including a second wedge, the second wedge having a second surface, wherein the first surface is operatively arranged to engage the second surface to displace the superior component relative to the inferior component. The surfaces of the wedges may be angled and include a plurality of corrugations or steps which engage to allow the implant to expand and collapse.

28 Claims, 14 Drawing Sheets

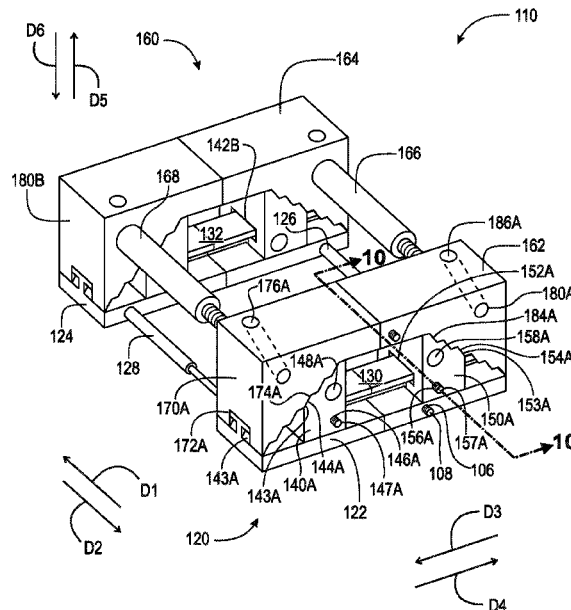

(56)

References Cited

U.S. PATENT DOCUMENTS

2005/0256576	A1	11/2005	Moskowitz et al.	
2008/0140207	A1*	6/2008	Olmos	A61F 2/4657 623/17.16
2009/0222100	A1*	9/2009	Cipoletti	A61F 2/4611 623/17.16
2013/0190876	A1	7/2013	Drochner et al.	
2015/0073552	A1*	3/2015	To	A61F 2/4611 623/17.15
2016/0025629	A1	1/2016	Kettler et al.	
2016/0256291	A1*	9/2016	Miller	A61F 2/4611
2018/0078384	A1	3/2018	Suddaby	
2018/0193164	A1*	7/2018	Shoshtaev	A61F 2/4425
2018/0207002	A1	7/2018	Glerum et al.	
2018/0318101	A1	11/2018	Engstrom	
2019/0029841	A1	1/2019	Suh et al.	
2019/0053912	A1	2/2019	Suddaby	

* cited by examiner

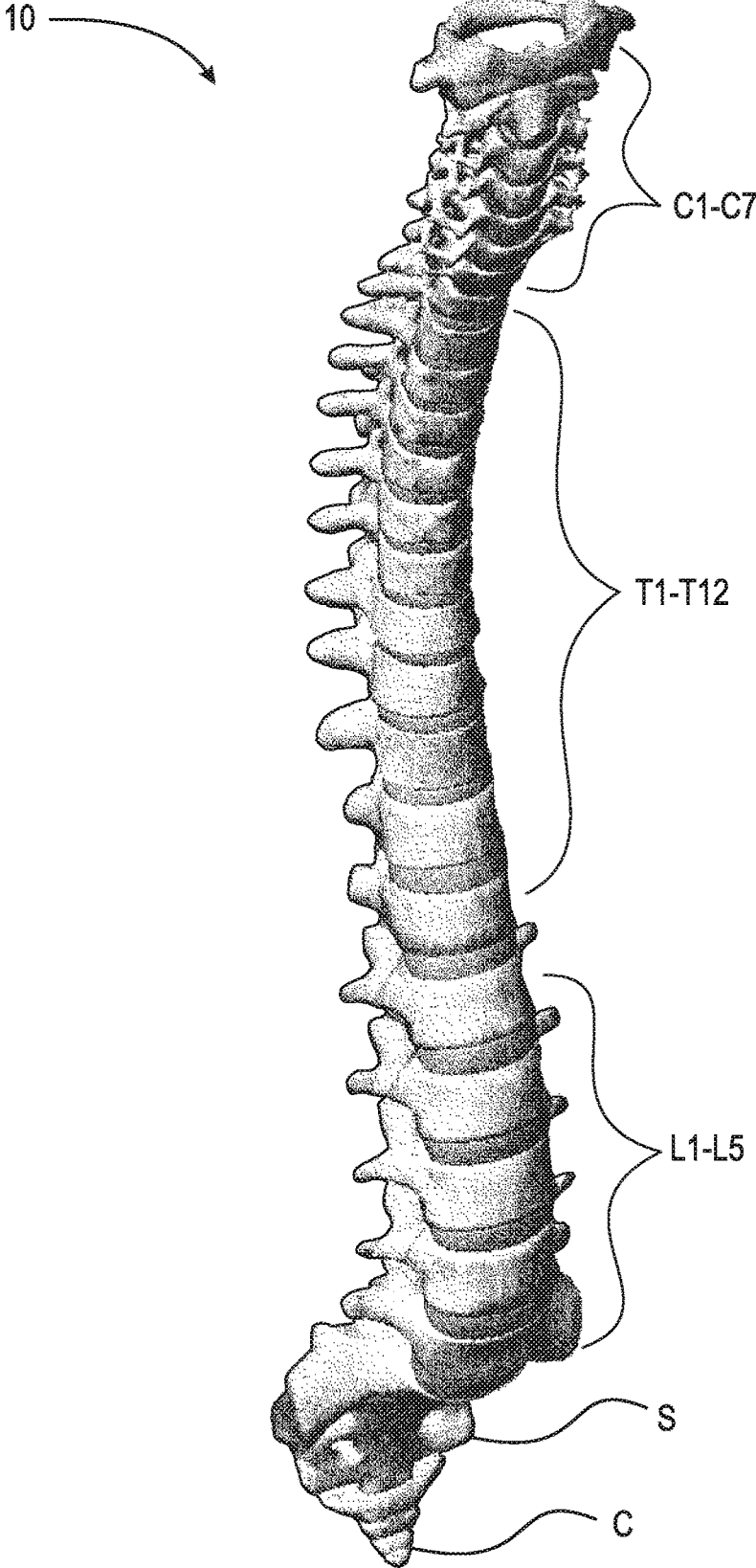

Fig. 1

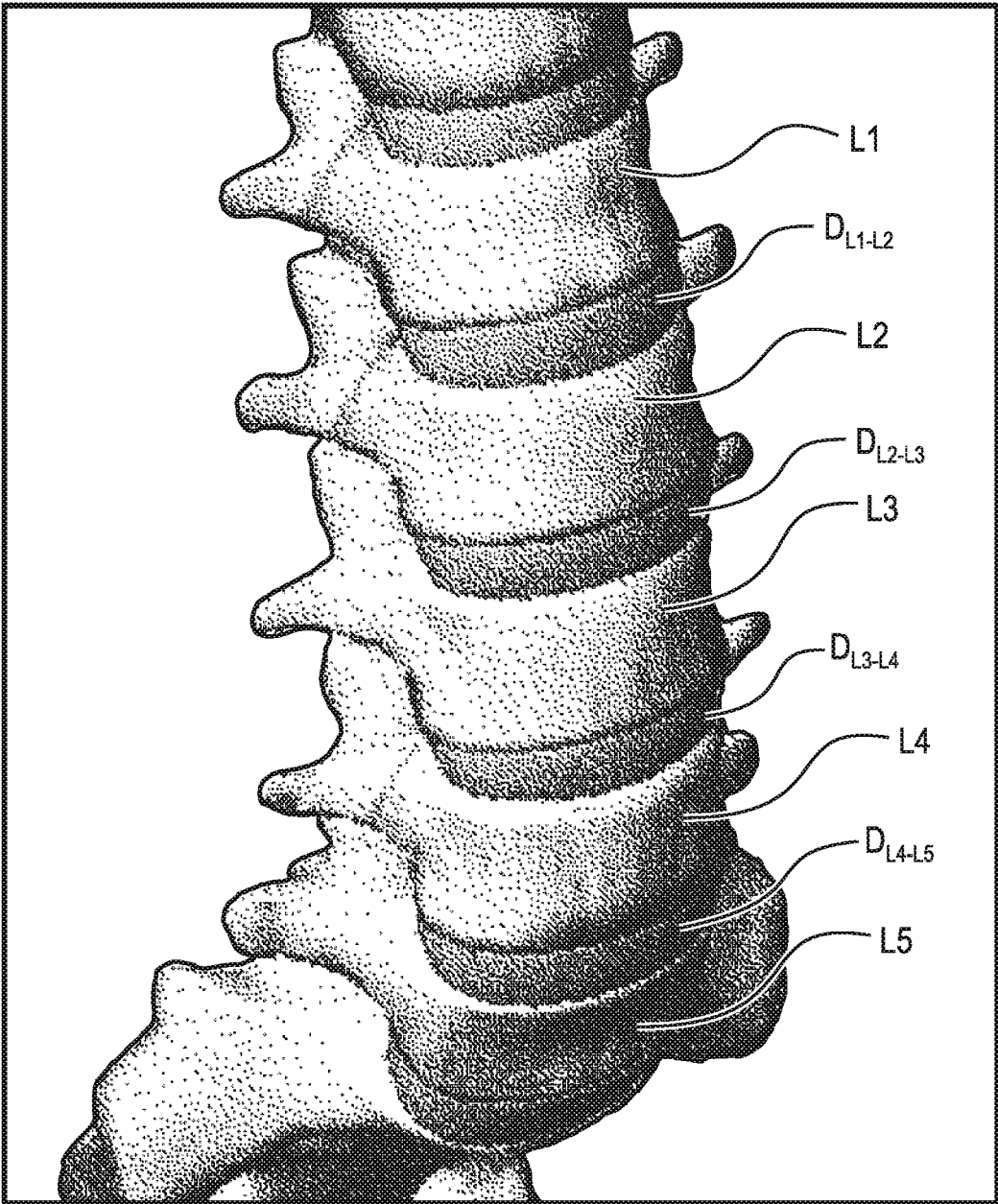

Fig. 2

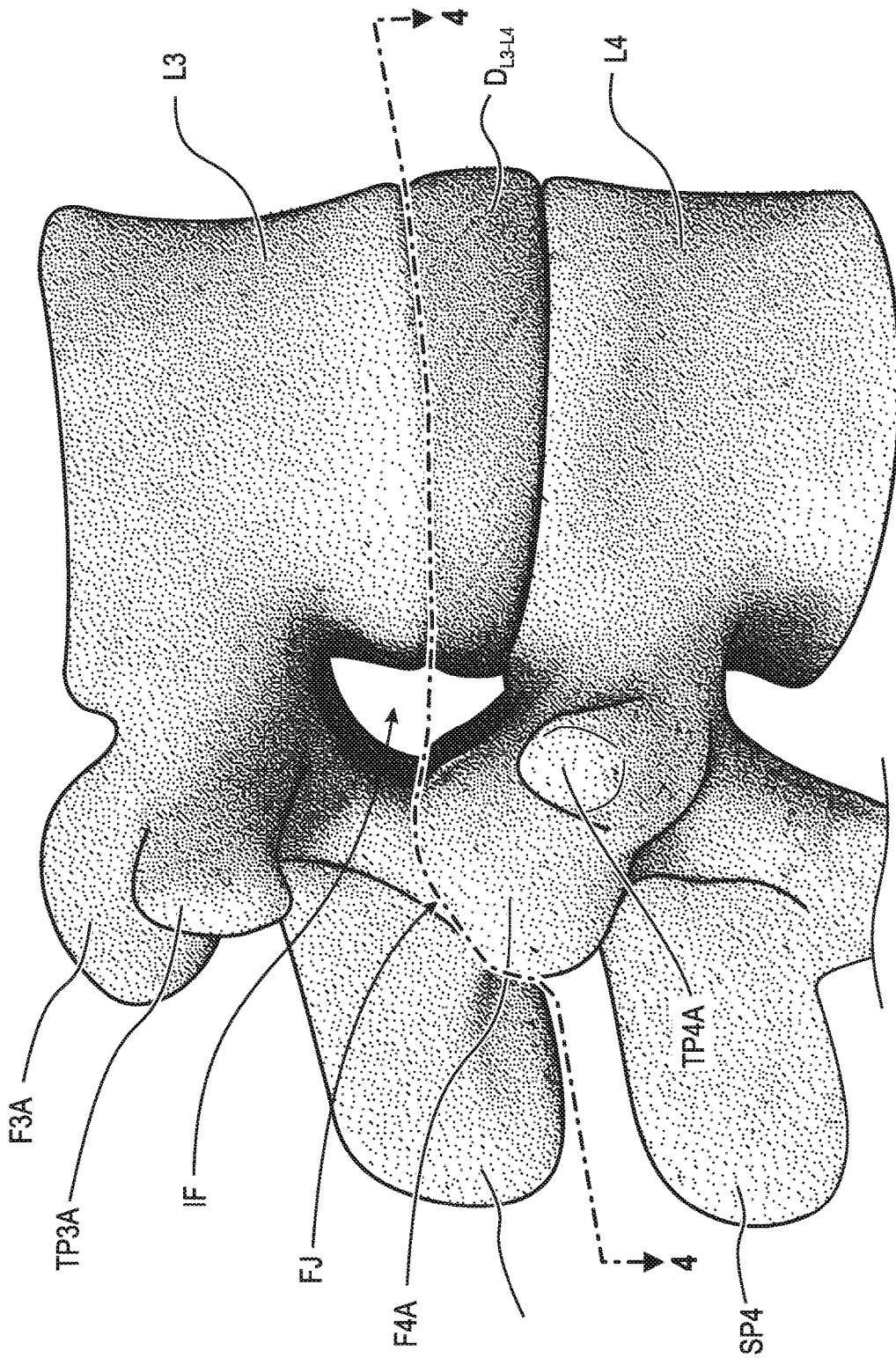

Fig. 3

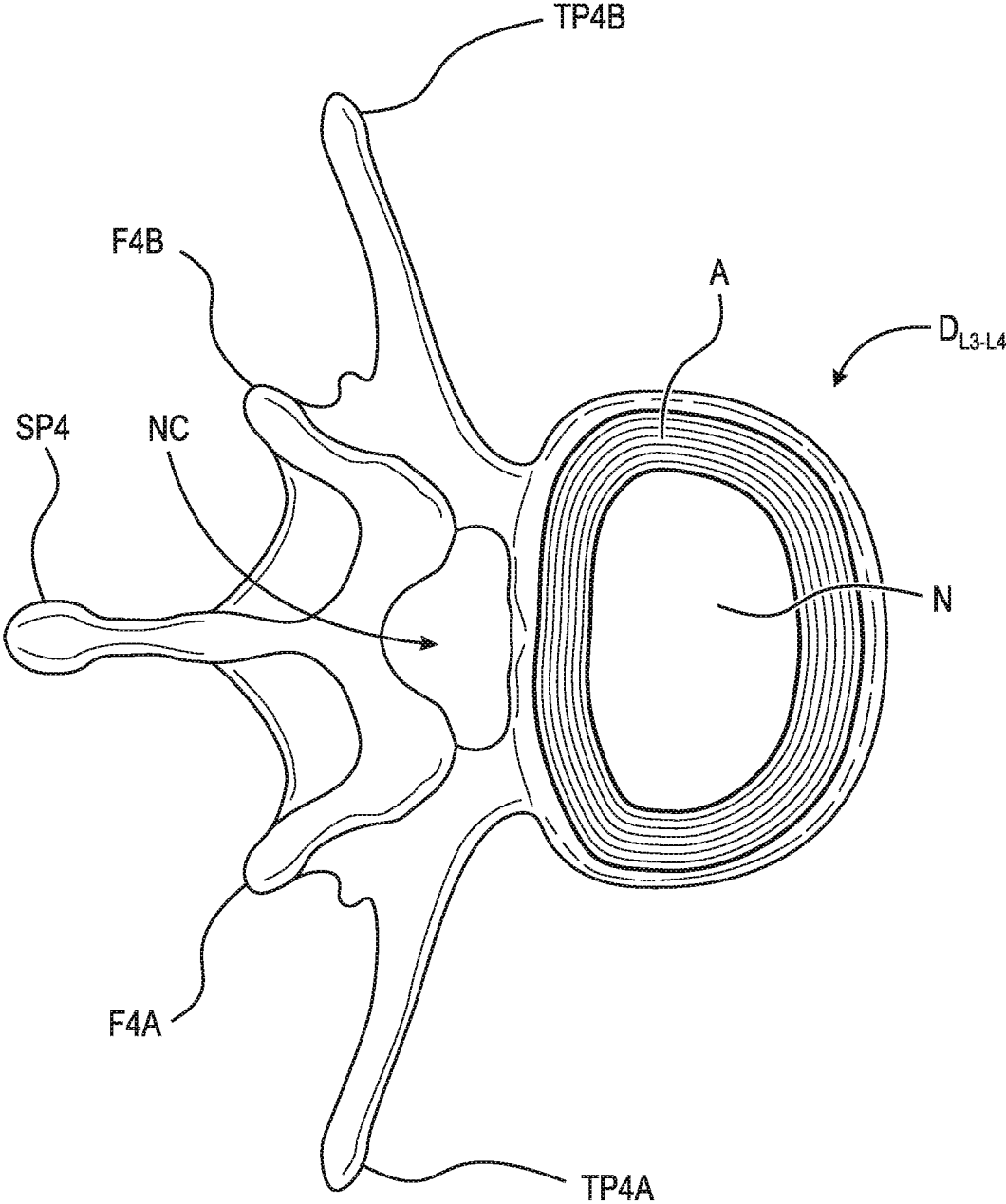

Fig. 4

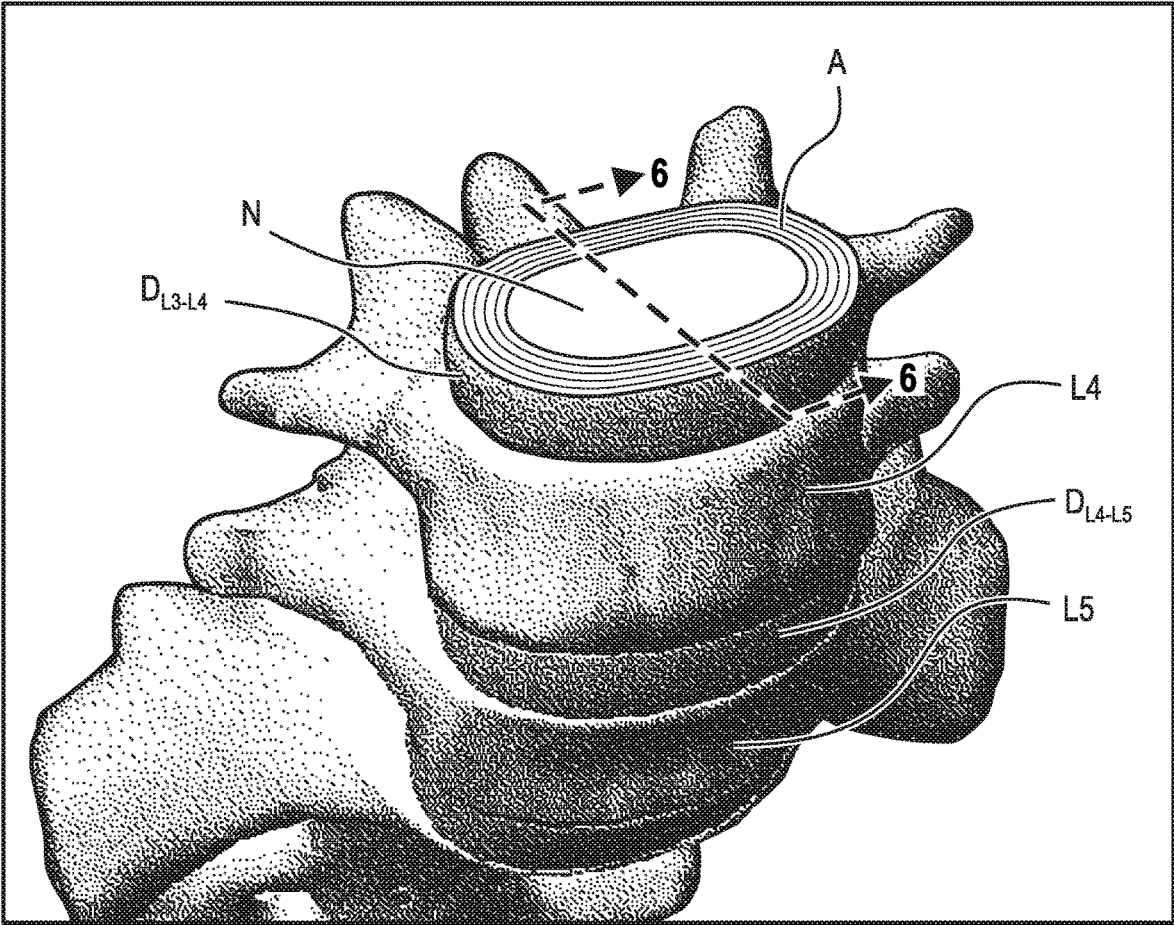

Fig. 5

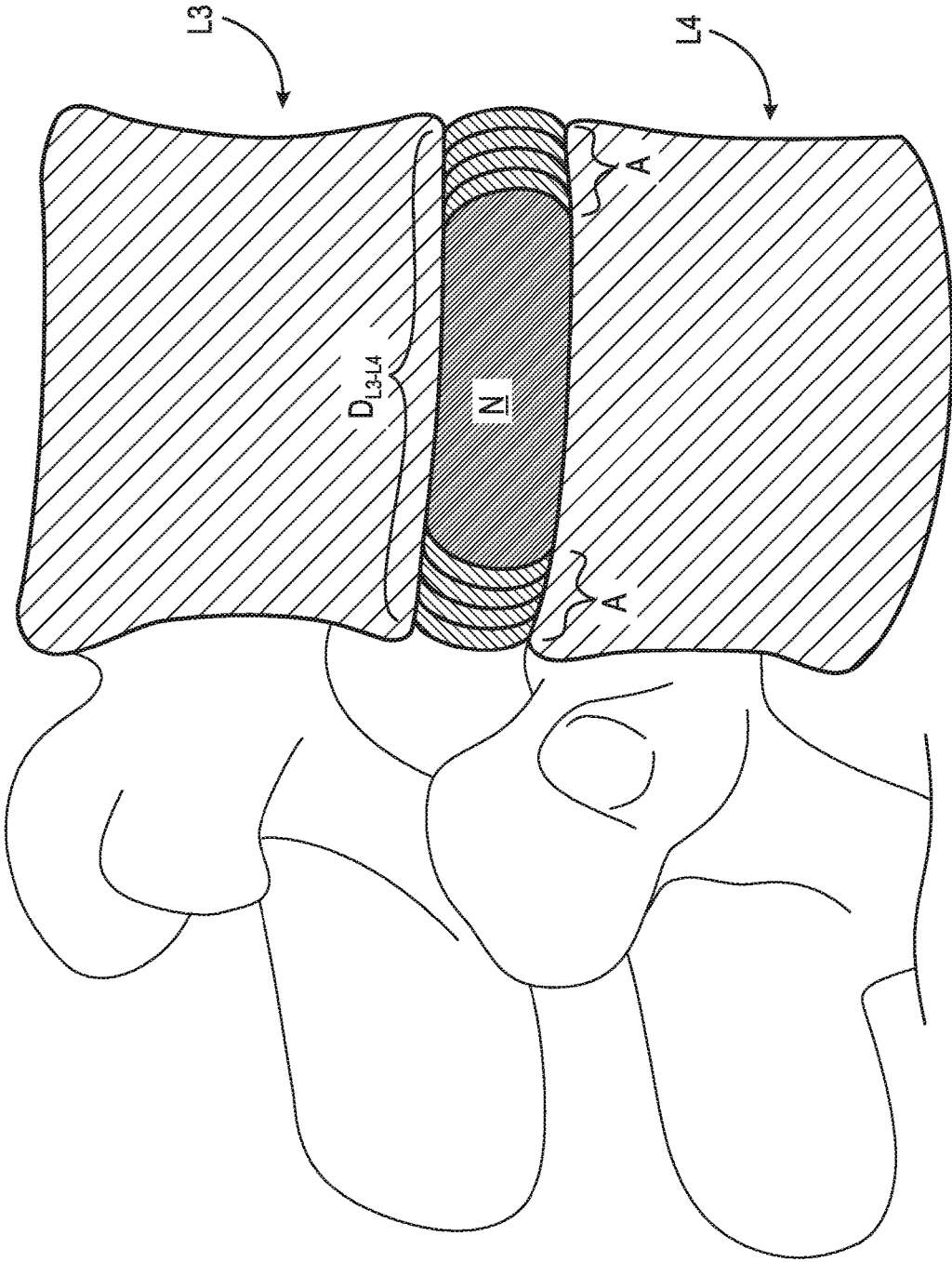

Fig. 6

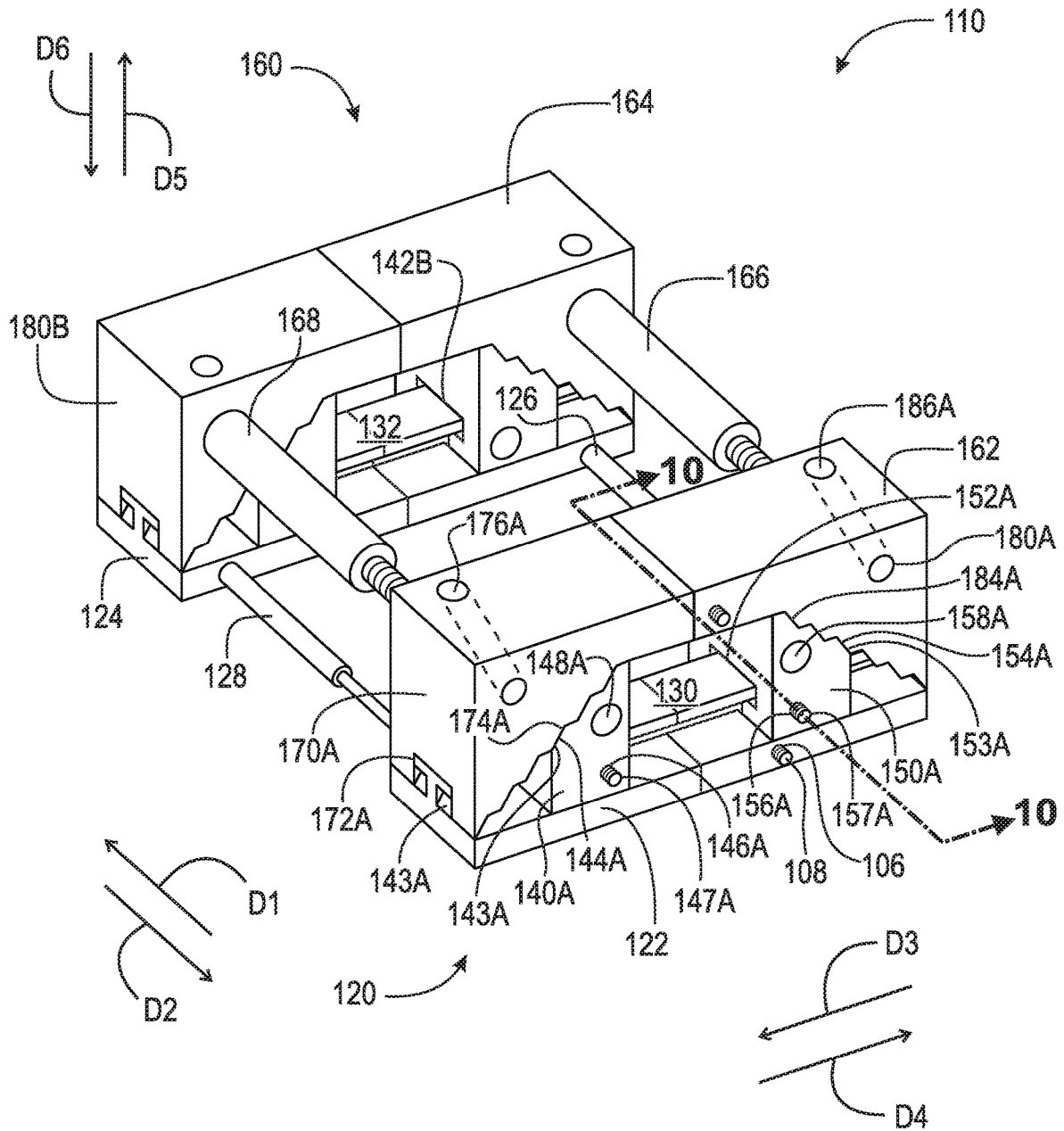

Fig. 7

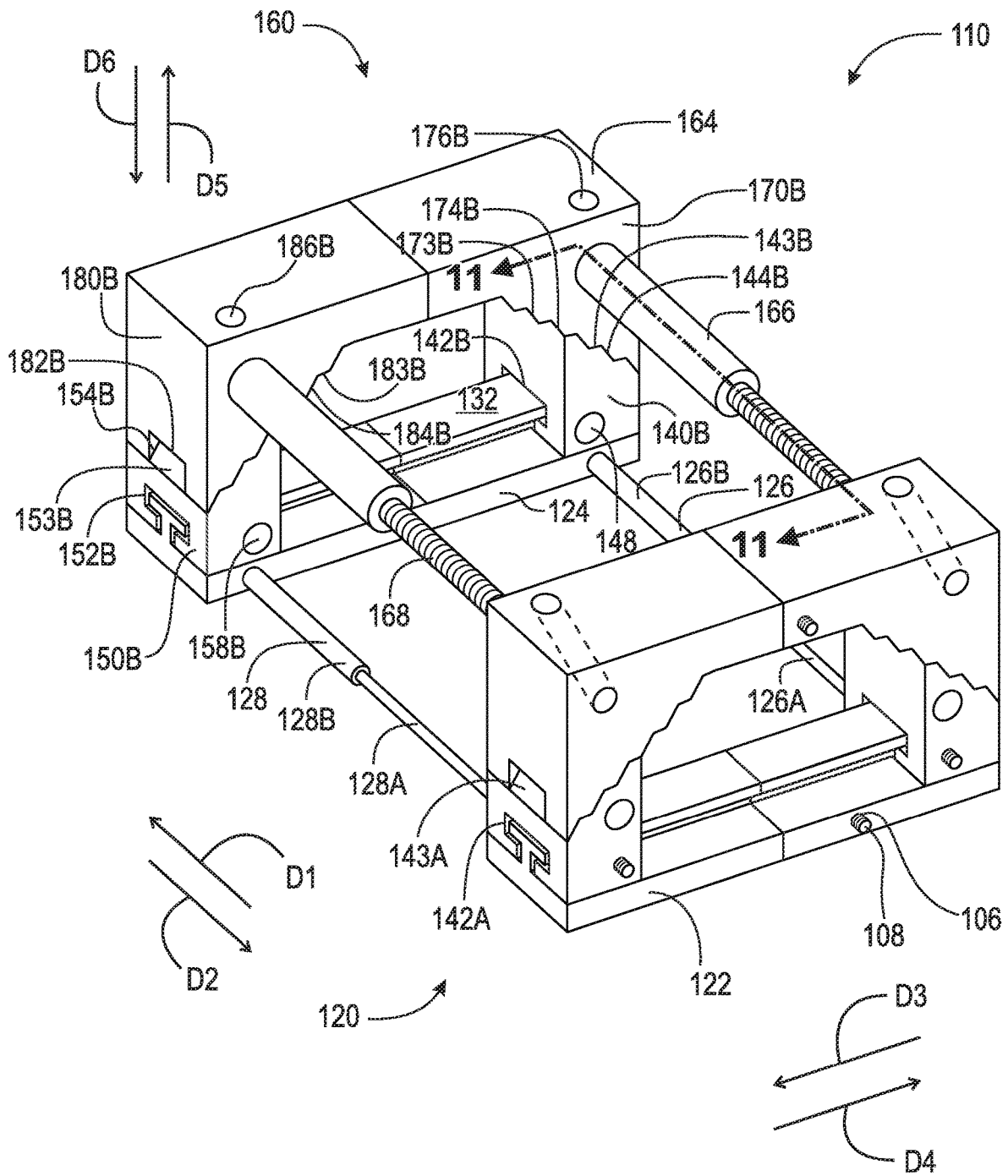

Fig. 8

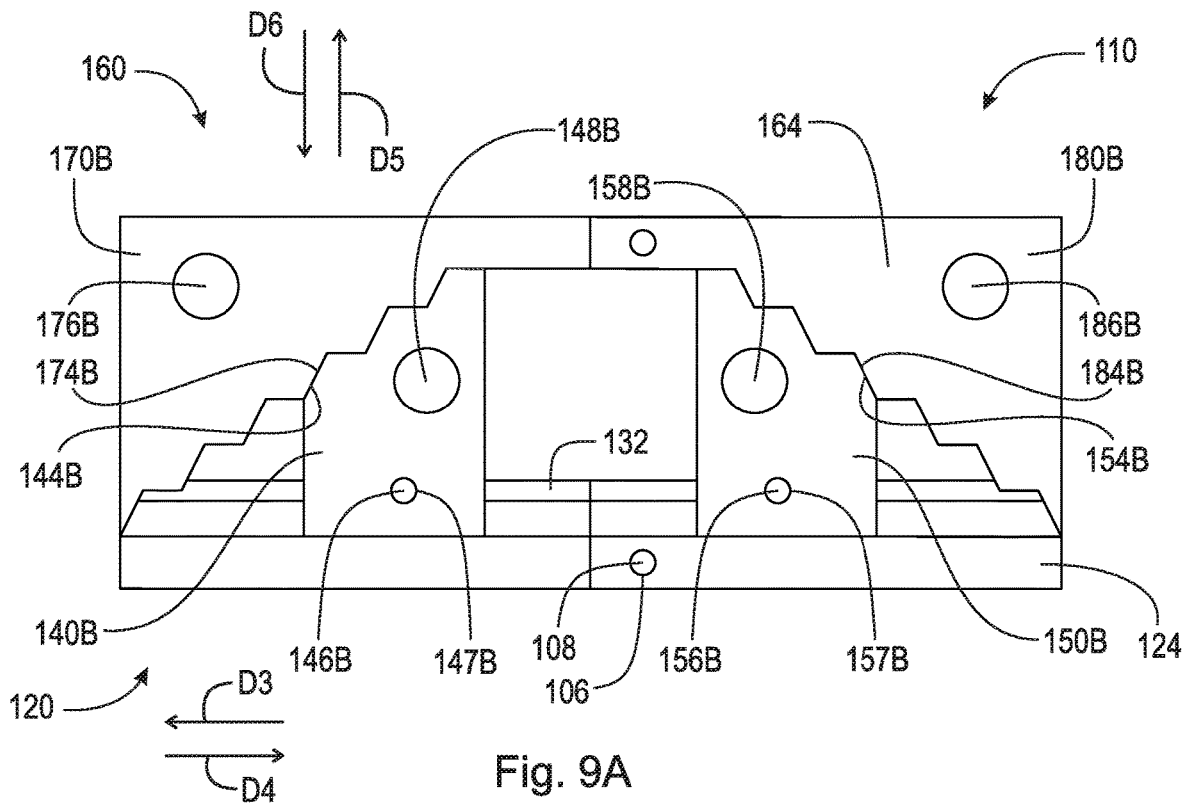

Fig. 9A

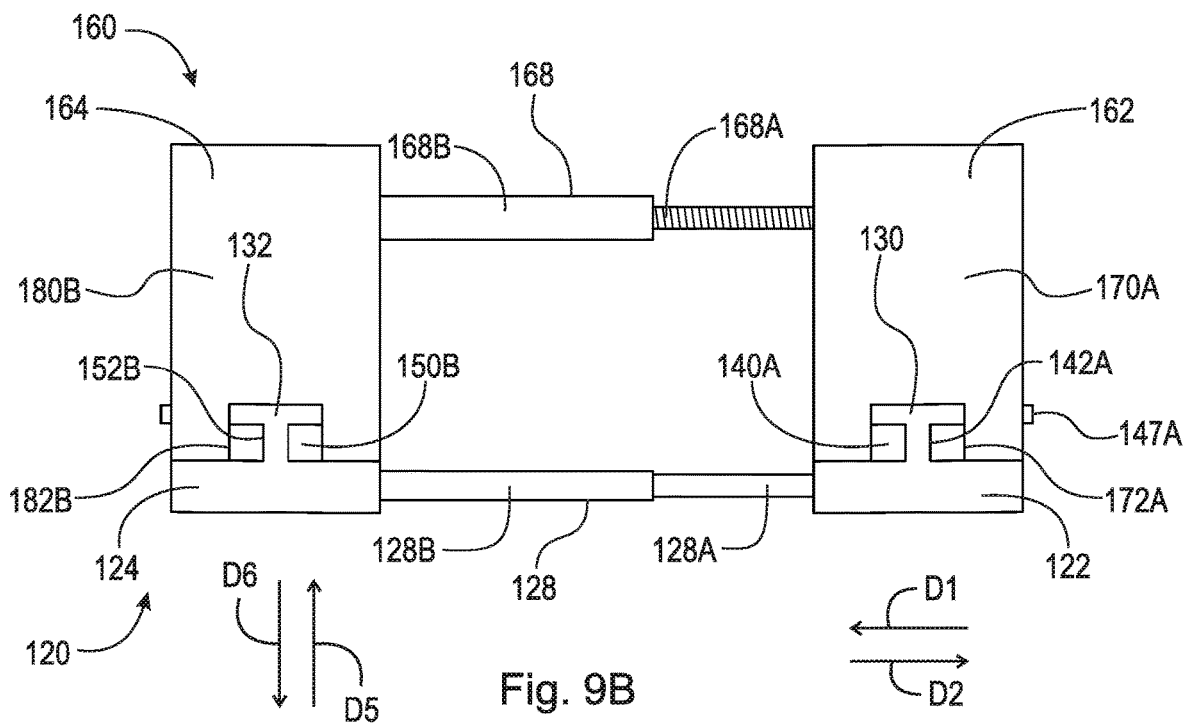

Fig. 9B

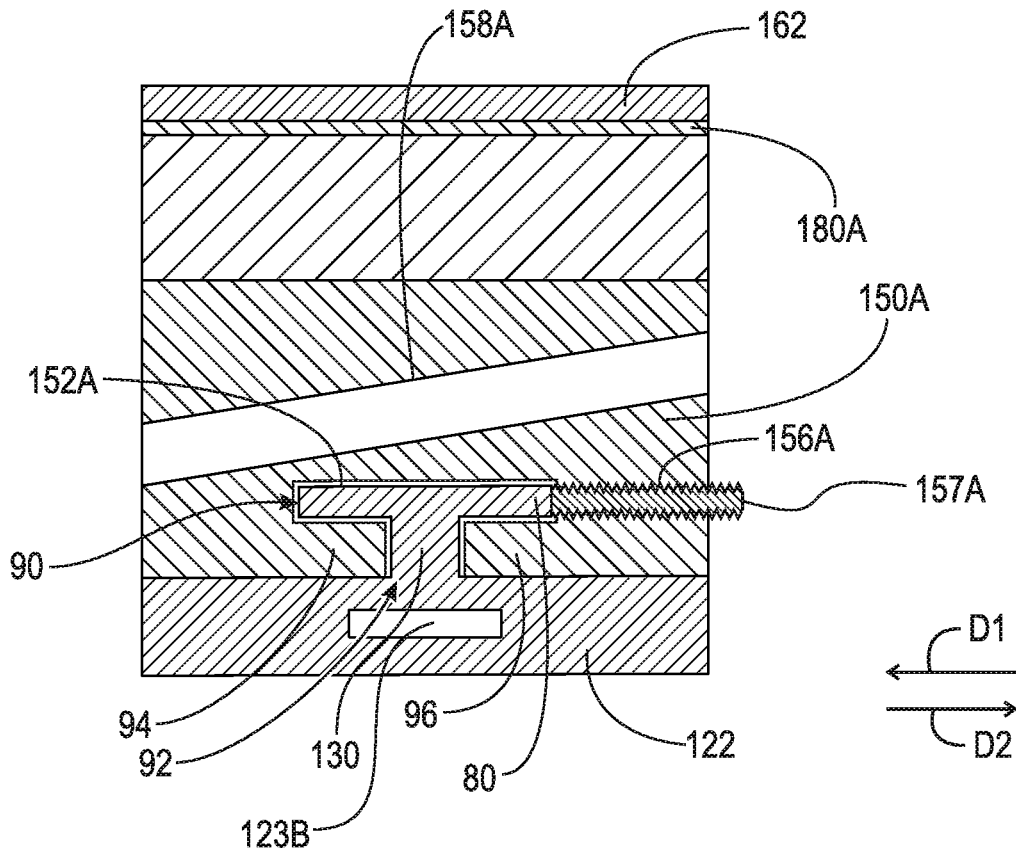

Fig. 10

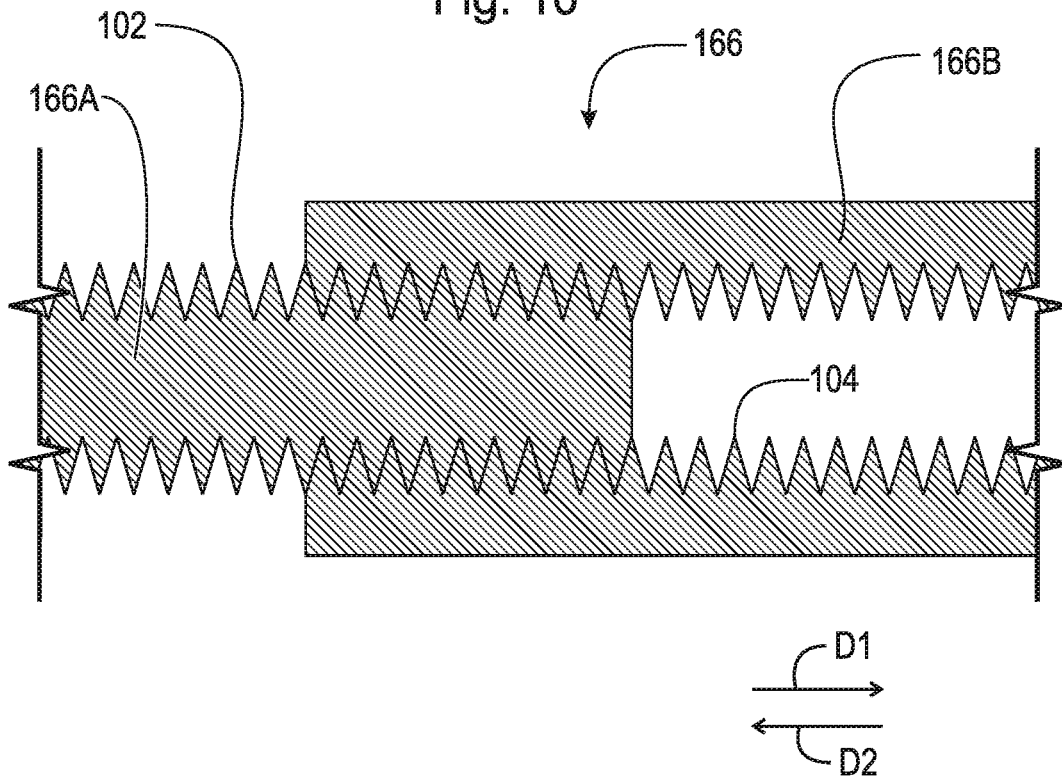

Fig. 11

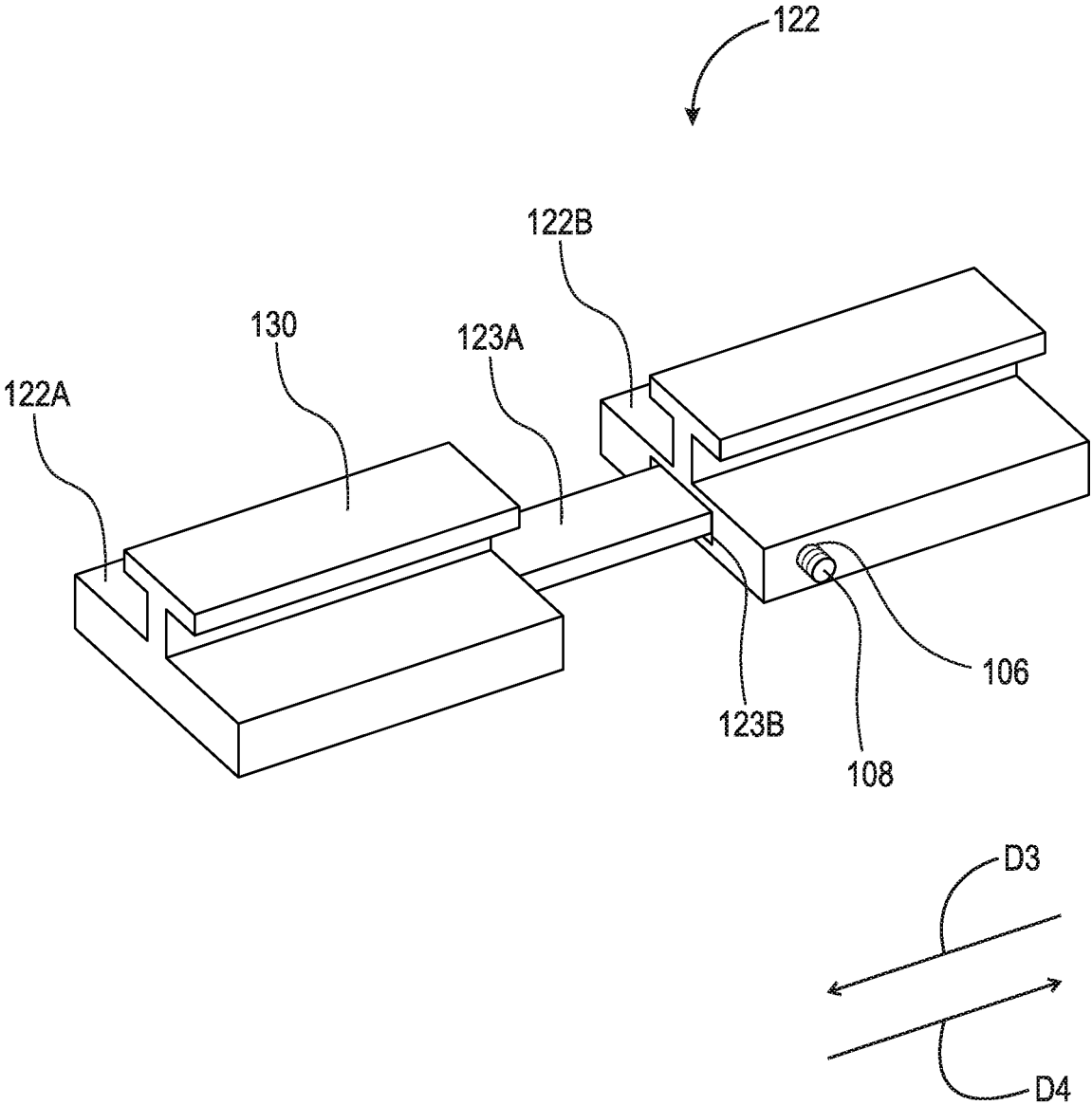

Fig. 12

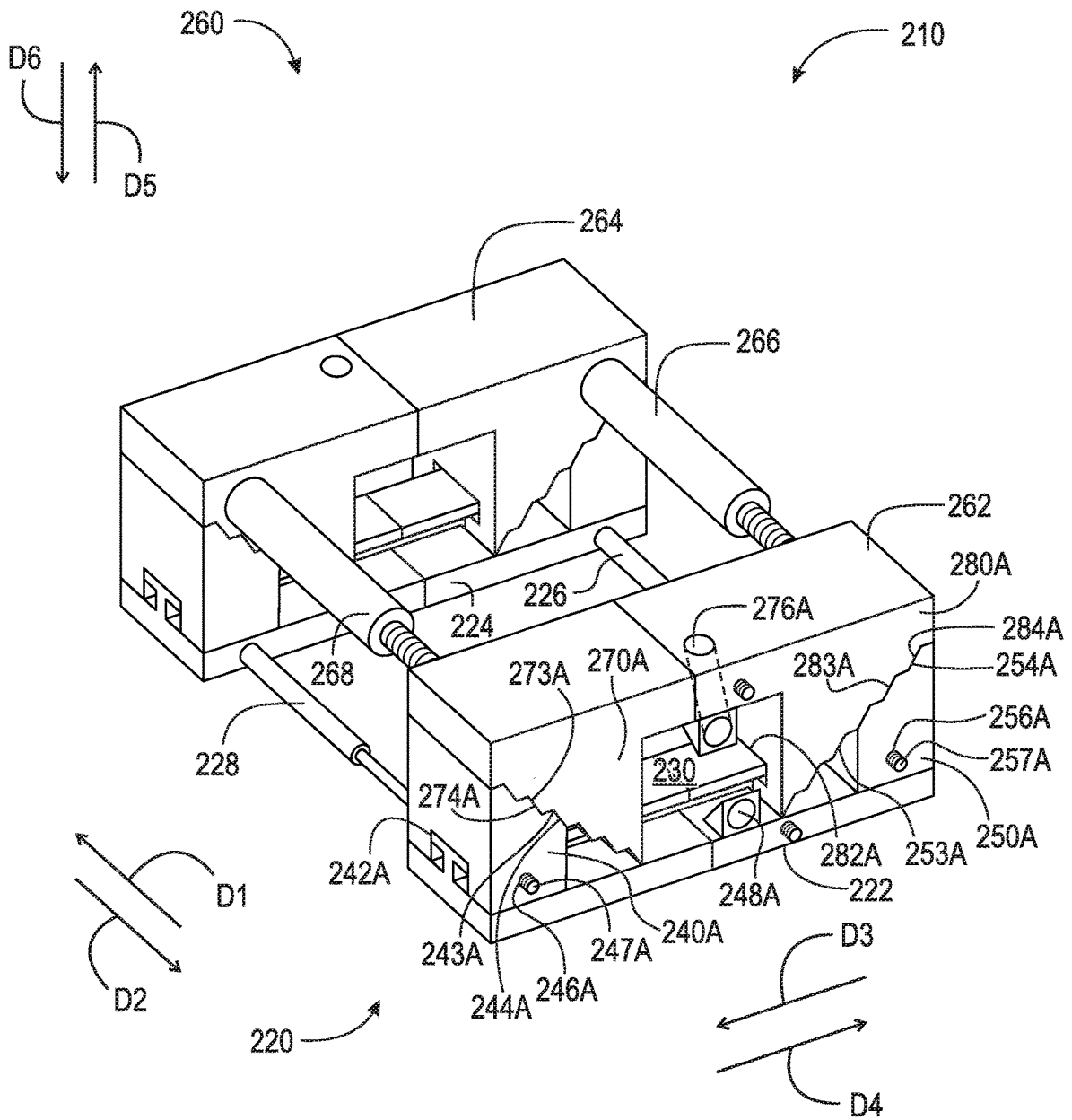

Fig. 13

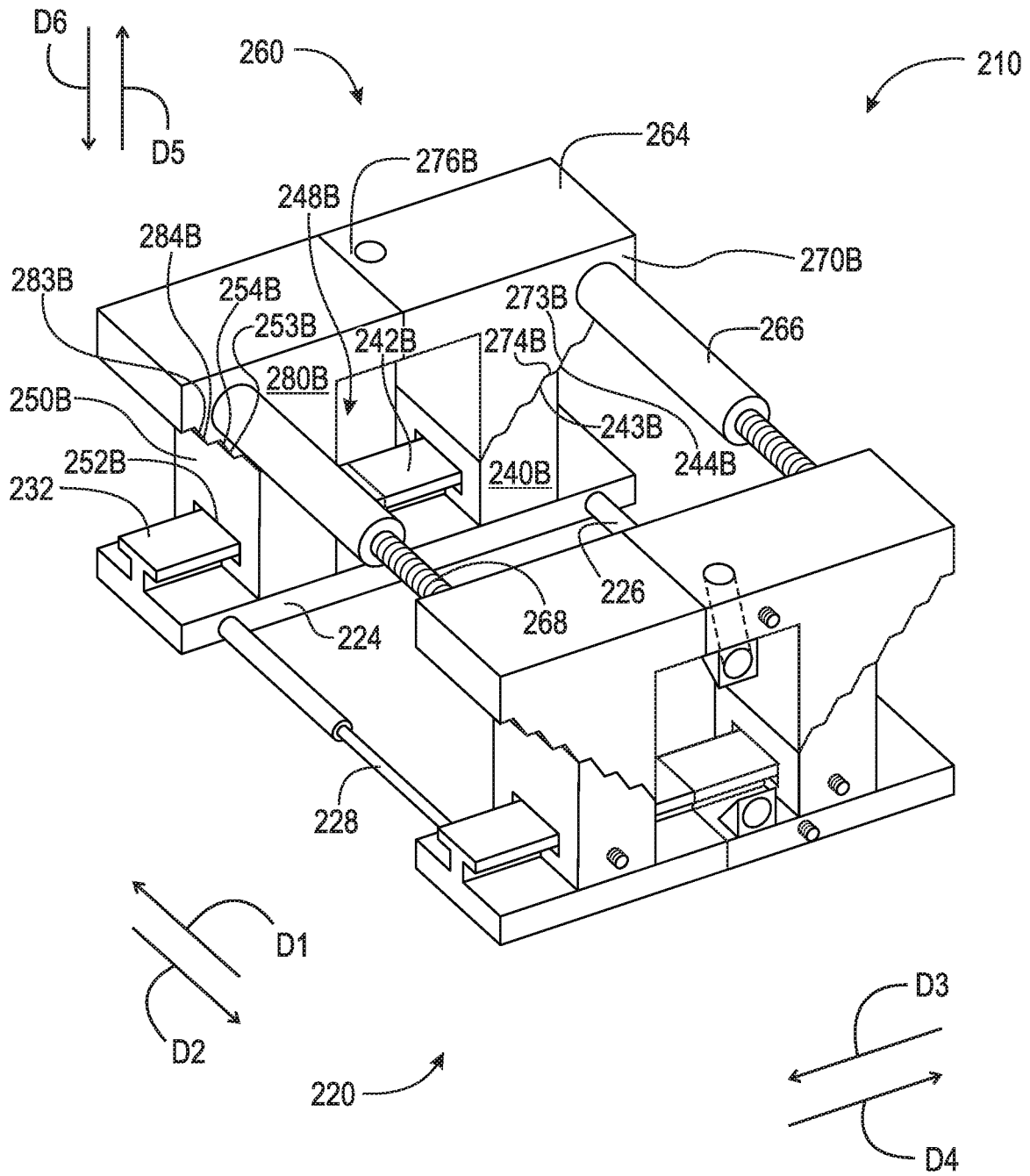

Fig. 14

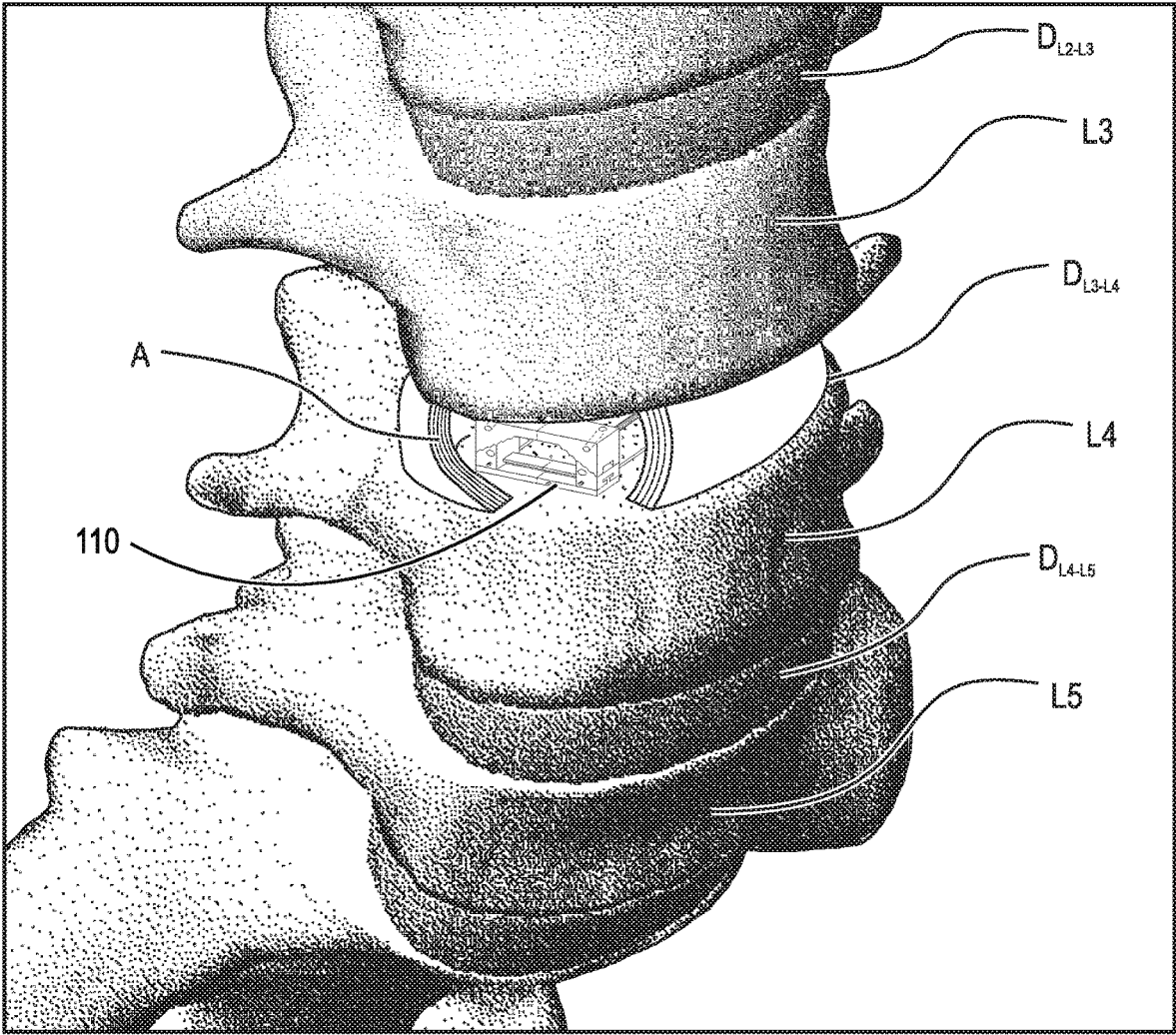

Fig. 15

EXPANDABLE INTERVERTEBRAL FUSION IMPLANT

FIELD

The present disclosure relates to orthopedic surgery, and more particularly to an expandable and deployable intervertebral fusion implant capable of being placed within an intervertebral disc space and expanded in vertical and lateral dimensions.

BACKGROUND

The spinal column, or backbone, is one of the most important parts of the body. It provides the main support, allowing us to stand upright, bend, and twist. As shown in FIG. 1, thirty three (33) individual bones interlock with each other to form the spinal column. The vertebrae are numbered and divided into regions. The cervical vertebrae C1-C7 form the neck, support the head and neck, and allow nodding and shaking of the head. The thoracic vertebrae T1-T12 join with the ribs to form the rib cage. The five lumbar vertebrae L1-L5 carry most of the weight of the upper body and provide a stable center of gravity when a person moves. Five vertebrae of the sacrum S and four of the coccyx C are fused. This comprises the back wall of the pelvis. Intervertebral discs are located between each of the mobile vertebra. Intervertebral discs comprise a thick outer layer with a crisscrossing fibrous structure annulus A that surrounds a soft gel-like center, the nucleus N. Discs function like shock-absorbing springs. The annulus pulls the vertebral bodies together against the elastic resistance of the gel-filled nucleus. When we bend, the nucleus acts like a ball bearing, allowing the vertebral bodies to roll over the incompressible gel. Each disc works in concert with two facet joints, forming a spinal motion segment. The biomechanical function of each pair of facet joints is to guide and limit the movement of the spinal motion segment. The surfaces of the joint are coated with cartilage that helps each joint move smoothly. Directly behind the discs, the ring-like vertebral bodies create a vertical tunnel called the spinal canal or neuro canal. The spinal cord and spinal nerves pass through the spinal canal, which protects them from injury. The spinal cord is the major column of nerve tissue that is connected to the brain and serves as an information super-highway between the brain and the body. The nerves in the spinal cord branch off to form pairs of nerve roots that travel through the small openings between the vertebrae and the intervertebral foramina.

Various medical conditions require a surgeon to repair, remove and/or replace the aforementioned discs. For example, in one surgical procedure, known as a discectomy (or diskectomy) with interbody fusion, the surgeon removes the nucleus of the disc and replaces it with an implant. As shown in FIG. 2, it may be necessary, for example, for the surgeon to remove the nucleus of the disc between the L3 and L4 vertebrae. Disc D_{L3-L4} is shown in an enlarged view in FIG. 3. This figure also shows various anatomical structures of the spine, including facets F3A and F4A, facet joint FJ, spinous processes SP3 (not shown) and SP4, transverse processes TP3A and TP4A, and intervertebral foramen IF. FIG. 4 is a top view of the section of the spinal column shown in FIG. 3, with the L3 vertebra removed to expose annulus A and nucleus N of disc D_{L3-L4} . Neural canal NC is also shown. FIG. 5 is an anterior perspective view of the section of the spinal column shown in FIG. 4. FIG. 6 is a partial cross-sectional view of the section of the spinal

column shown in FIG. 5, taken generally along line 6-6, but with vertebra L3 in place atop disc D_{L3-L4} .

Of all animals possessing a backbone, human beings are the only creatures who remain upright for significant periods of time. From an evolutionary standpoint, this erect posture has conferred a number of strategic benefits, not the least of which is freeing the upper limbs for purposes other than locomotion. From an anthropologic standpoint, it is also evident that this unique evolutionary adaptation is a relatively recent change, and as such has not benefitted from natural selection as much as have backbones held in a horizontal attitude. As a result, the stresses acting upon the human backbone (or "vertebral column"), are unique in many senses, and result in a variety of problems or disease states that are peculiar to the human species.

The human vertebral column is essentially a tower of bones held upright by fibrous bands called ligaments and contractile elements called muscles. There are seven bones in the neck or cervical region, twelve in the chest or thoracic region, five in the lower back or lumbar region, and five in the pelvic or sacral region, which are normally fused together to form the back part of the pelvis. This column of bones is critical for providing structural support for the entire body.

Between the vertebral bones themselves exist soft tissue structures, i.e., discs, composed of fibrous tissue and cartilage that are compressible and act as shock absorbers for sudden downward forces on the upright column. The discs allow the bones to move independently of each other, as well. The repetitive forces which act on these intervertebral discs during repetitive activities of bending, lifting, and twisting cause them to break down or degenerate over time.

Presumably, because of humans' upright posture their intervertebral discs have a high propensity to degenerate. Overt trauma or covert trauma, occurring in the course of repetitive activities, disproportionately affects the more highly mobile areas of the spine. Disruption of a disc's internal architecture leads to bulging, herniation, or protrusion of pieces of the disc and eventual disc space collapse. Resulting mechanical and even chemical irritation of surrounding neural elements (spinal cord and nerves) cause pain, attended by varying degrees of disability. In addition, loss of disc space height relaxes tension on the longitudinal spinal ligaments, thereby contributing to varying degrees of spinal instability.

The time-honored method of addressing the issues of neural irritation and instability resulting from severe disc damage has largely focused on removal of the damaged disc and fusing the adjacent vertebral elements together. Removal of the disc relieves the mechanical and chemical irritation of neural elements, while osseous union (i.e., bone knitting) solves the problem of stability.

While cancellous bone appears ideal to provide the biologic components necessary for osseous union to occur, it does not initially have the strength to resist the tremendous forces that may occur in the intervertebral disc space, nor does it have the capacity to adequately stabilize the spine until long term bony union occurs. For these reasons, many spinal surgeons have found that interbody fusion using bone alone has an unacceptably high rate of bone graft migration or even expulsion or nonunion due to structural failure of the bone or residual degrees of motion that retard or prohibit bony union. Intervertebral prosthesis in various forms have therefore been used to provide immediate stability and to protect and preserve an environment that fosters growth of the grafted bone such that a structurally significant bony fusion can occur.

U.S. Pat. No. 5,505,732 (Michelson), U.S. Pat. No. 5,653,761 (Pisharodi I), U.S. Pat. No. 5,665,122 (Kambin), and U.S. Pat. No. 5,683,463 (Godefroy et al.) disclose different prior art spinal implants. The implant disclosed in U.S. Pat. No. 5,483,463 (Qin et al.) is hollow and tubular, with communicating windows in the top and bottom surfaces. External ribs, which may be serrated, stabilize the implant once it is inserted between the vertebrae. Kambin discloses an intervertebral cage that is expandable by a wedging mechanism. The degree of expansion is rather limited. Michelson and U.S. Pat. No. 5,653,762 (Pisharodi II) disclose shaft-type tools used for installing implants. The prior art devices do not enable one to achieve great ranges of implant height.

Limitations of most present-day intervertebral implants are significant and revolve largely around the marked variation in the disc space height and shape that result from either biologic variability or pathologic change. For example, if a disc space is 20 mm in height, a circular implant bridging this gap requires a minimum diameter of 20 mm just to contact the end plate of the vertebral bone. Generally, end plate disruption must occur to allow a generous bony union, meaning that an additional 2-3 mm must be added on either side resulting in a final implant size of 24-26 mm. During implantation from an anterior approach (i.e., from the front of the body), excessive retraction (or pulling) is often required on the great blood vessels, which greatly enhances the risk of devastating complications such as vascular tears or thrombosis. On the other hand, during a posterior approach, large implant diameters may require excessive traction on neural elements for adequate placement, even if all posterior bony elements are removed. In some instances, an adequate implant size cannot be inserted posteriorly, particularly if there is a significant degree of distraction required to obtain stability by tautening the annular ligamentous band. Compromising on implant size risks sub-optimal stability or a loose implant, which has a greater risk of migration within, or expulsion from, the disc space. The alternative of excessively retracting neural elements to facilitate a posterior implant application results in a neuropraxia at best and permanent neural damage at worst.

U.S. Pat. No. 6,174,334 (Suddaby I) and U.S. Pat. No. 6,332,895 (Suddaby II) disclose expandable cages using a ratcheting mechanism in the perimeter to achieve expansion. The aforementioned Suddaby patents do not address issues requiring lateral expansion.

Thus, there is a long-felt need for an expandable and deployable intervertebral fusion implant capable of being placed within an intervertebral disc space and expanded in vertical and lateral dimensions.

SUMMARY

According to aspects illustrated herein, there is provided an expandable intervertebral fusion implant, comprising an inferior component, including a plate, and a first wedge slidably connected to the plate, the first wedge having a first surface, and a superior component including a second wedge, the second wedge having a second surface, wherein the first surface is operatively arranged to engage the second surface to displace the superior component relative to the inferior component.

According to aspects illustrated herein, there is provided an expandable intervertebral fusion implant, comprising an inferior component, including a first plate, a first wedge slidably connected to the first plate, the first wedge having a first surface, a second plate, a second wedge slidably

connected to the second plate, the second wedge having a second surface, and at least one first cross-member connecting the first and second plates, and a superior component, including a first component including a third wedge, the third wedge having a third surface, a second component including a fourth wedge, the fourth wedge having a fourth surface, and at least one second cross-member connecting the first and second components, wherein the first and second surfaces are operatively arranged to engage the third and fourth surfaces, respectively, to displace the superior component relative to the inferior component.

These and other objects, features, and advantages of the present disclosure will become readily apparent upon a review of the following detailed description of the disclosure, in view of the drawings and appended claims.

BRIEF DESCRIPTION OF THE DRAWINGS

Various embodiments are disclosed, by way of example only, with reference to the accompanying schematic drawings in which corresponding reference symbols indicate corresponding parts, in which:

FIG. 1 is an anterior perspective view of a spinal column;

FIG. 2 is an anterior perspective view of the lumbar section of the spinal column shown in FIG. 1;

FIG. 3 is a lateral perspective view of two vertebrae, a disc, and related spinal anatomy;

FIG. 4 is a top view of a section of the spinal column, taken generally along line 4-4 in FIG. 3;

FIG. 5 is an enlarged anterior perspective view of the spinal column shown in FIG. 2, except with the top vertebra and all other structure above the top vertebra removed;

FIG. 6 is a partial cross-sectional view of the top and bottom vertebrae and disc, taken generally along line 6-6 in FIG. 5;

FIG. 7 is a front perspective view of an expandable intervertebral fusion implant, in a fully collapsed state;

FIG. 8 is a front perspective view of the expandable intervertebral fusion implant shown in FIG. 7, in an expanded state;

FIG. 9A is a rear elevational view of the expandable intervertebral fusion implant shown in FIG. 7;

FIG. 9B is a side elevational view of the expandable intervertebral fusion implant shown in FIG. 7;

FIG. 10 is a cross-sectional view of a tongue and groove connection taken generally along line 10-10 in FIG. 7;

FIG. 11 is a cross-sectional view of a cross-member taken generally along line 11-11 in FIG. 8;

FIG. 12 is a perspective view of a plate in an expanded state;

FIG. 13 is a front perspective view of an expandable intervertebral fusion implant, in a fully collapsed state;

FIG. 14 is a front perspective view of the expandable intervertebral fusion implant shown in FIG. 13, in an expanded state; and,

FIG. 15 is an anterior perspective view of a spinal column including the expandable intervertebral fusion implant shown in FIG. 7.

DETAILED DESCRIPTION

At the outset, it should be appreciated that like drawing numbers on different drawing views identify identical, or functionally similar, structural elements. It is to be understood that the claims are not limited to the disclosed aspects.

Furthermore, it is understood that this disclosure is not limited to the particular methodology, materials and modi-

fications described and as such may, of course, vary. It is also understood that the terminology used herein is for the purpose of describing particular aspects only, and is not intended to limit the scope of the claims.

Unless defined otherwise, all technical and scientific terms used herein have the same meaning as commonly understood to one of ordinary skill in the art to which this disclosure pertains. It should be understood that any methods, devices or materials similar or equivalent to those described herein can be used in the practice or testing of the example embodiments. The assembly of the present disclosure could be driven by hydraulics, electronics, pneumatics, and/or springs.

It should be appreciated that the term “substantially” is synonymous with terms such as “nearly,” “very nearly,” “about,” “approximately,” “around,” “bordering on,” “close to,” “essentially,” “in the neighborhood of,” “in the vicinity of,” etc., and such terms may be used interchangeably as appearing in the specification and claims. It should be appreciated that the term “proximate” is synonymous with terms such as “nearby,” “close,” “adjacent,” “neighboring,” “immediate,” “adjoining,” etc., and such terms may be used interchangeably as appearing in the specification and claims. The term “approximately” is intended to mean values within ten percent of the specified value.

Adverting now to the figures, and as described previously, FIGS. 1-6 depict various parts and sections of spinal anatomy.

FIG. 7 is a front perspective view of expandable intervertebral fusion implant 110, in a fully collapsed state. FIG. 8 is a front perspective view of expandable intervertebral fusion implant 110, in an expanded state. FIG. 9A is a rear elevational view of expandable intervertebral fusion implant 110. FIG. 9B is a side elevational view of expandable intervertebral fusion implant 110. Expandable intervertebral fusion implant 110 generally comprises inferior component 120 and superior component 160. The following description should be read in view of FIGS. 7-9B.

Inferior component 120 comprises plate 122, plate 124, cross-member 126, cross-member 128, wedges 140A-B, and wedges 150A-B. In some embodiments, inferior component 120 comprises only plate 122, wedge 140A, and wedge 150A.

Wedges 140A and 150A are slidably engaged with plate 122. In some embodiments, and as shown in the figures, plate 122 comprises rail 130, and wedges 140A and 150A are slidably connected to rail 130. In some embodiments, plate 122 is expandable, as will be discussed in greater detail below with respect to FIG. 12.

Wedge 140A comprises groove 142A and teeth 144A arranged on angled surface 143A. In the embodiment shown in FIGS. 7-12, wedge 140A decreases in height in direction D3 (i.e., surface 143A slopes downward in direction D3). Groove 142A is operatively arranged to engage rail 130, as will be discussed in greater detail below with respect to FIG. 10. Wedge 140A is arranged to displace relative to plate 122 in direction D3 and direction D4. Teeth 144A are operatively arranged to engage teeth 174A of wedge 170A of superior component 160 to expand expandable intervertebral fusion implant 110 and lock it at a set height, as will be discussed in greater detail below. In some embodiments, teeth 144A are stairs arranged on angled surface 143A, with each step of the stairs including a tread that is parallel to directions D3 and D4 and a riser that is arranged at an angle relative to directions D3 and D4. The arrangement of teeth 144A as stairs allows expandable intervertebral fusion implant 110 to expand (i.e., by way of the engagement of the angled risers)

and to at least partially lock or maintain at a certain height (i.e., by way of the engagement of the horizontal treads). The arrangement of the teeth 144A as stairs also allows expandable intervertebral fusion implant 110 to collapse. In some embodiments, teeth 144A are corrugations (i.e., ridges or grooves) arranged on angled surface 143A. Wedge 140A further comprises hole 146A and locking member 147A. As shown, locking member 147A is a set screw which engages threaded hole 146A in order to fixedly secure wedge 140A to rail 130, as will be discussed in greater detail below with respect to FIG. 10. It should be appreciated that any means suitable for fixedly securing wedge 140A to plate 122 may be used (e.g., a clamp, crimping the wedge about the rail to fixedly secure it thereto, adhesives, bolts, rivets, welding, soldering, etc.), and that the present disclosure should not be limited to just the use of a set screw. Wedge 140A may further comprise hole 148A for securing inferior component 120 to an adjacent vertebra with, for example, a bone screw. Hole 148A is arranged at an angle relative to plate 122, for example, generally in direction D6, and does not interfere with groove 142A or rail 130.

Wedge 150A comprises groove 152A and teeth 154A arranged on angled surface 153A. In the embodiment shown in FIGS. 7-12, wedge 150A decreases in height in direction D4 (i.e., surface 153A slopes downward in direction D4). Groove 152A is operatively arranged to engage rail 130, as will be discussed in greater detail below with respect to FIG. 10. Wedge 150A is arranged to displace relative to plate 122 in direction D3 and direction D4. Teeth 154A are operatively arranged to engage teeth 184A of wedge 180A of superior component 160 to expand expandable intervertebral fusion implant 110 and lock it at a set height, as will be discussed in greater detail below. In some embodiments, teeth 154A are stairs arranged on angled surface 153A, with each step of the stairs including a tread that is parallel to directions D3 and D4 and a riser that is arranged at an angle relative to directions D3 and D4. The arrangement of teeth 154A as stairs allows expandable intervertebral fusion implant 110 to expand (i.e., by way of the engagement of the angled risers) and to at least partially lock or maintain at a certain height (i.e., by way of the engagement of the horizontal treads). The arrangement of the teeth 154A as stairs also allows expandable intervertebral fusion implant 110 to collapse. In some embodiments, teeth 154A are corrugations (i.e., ridges or grooves) arranged on angled surface 153A. Wedge 150A further comprises hole 156A and locking member 157A. As shown, locking member 157A is a set screw which engages threaded hole 156A in order to fixedly secure wedge 150A to rail 130, as will be discussed in greater detail below with respect to FIG. 10. It should be appreciated that any means suitable for fixedly securing wedge 150A to plate 122 may be used (e.g., a clamp, crimping the wedge about the rail to fixedly secure it thereto, adhesives, bolts, rivets, welding, soldering, etc.), and that the present disclosure should not be limited to just the use of a set screw. Wedge 150A may further comprise hole 158A for securing inferior component 120 to an adjacent vertebra with, for example, a bone screw. Hole 158A is arranged at an angle relative to plate 122, for example, generally in direction D6, and does not interfere with groove 152A or rail 130.

Wedges 140B and 150B are slidably engaged with plate 124. In some embodiments, and as shown in the figures, plate 124 comprises rail 132, and wedges 140B and 150B are slidably connected to rail 132. In some embodiments, plate 124 is expandable, as will be discussed in greater detail below with respect to FIG. 12.

Wedge **140B** comprises groove **142B** and teeth **144B** arranged on angled surface **143B**. In the embodiment shown in FIGS. 7-12, wedge **140B** decreases in height in direction **D4** (i.e., surface **143B** slopes downward in direction **D3**). Groove **142B** is operatively arranged to engage rail **132**, as will be discussed in greater detail below with respect to FIG. **10**. Wedge **140B** is arranged to displace relative to plate **124** in direction **D3** and direction **D4**. Teeth **144B** are operatively arranged to engage teeth **174B** of wedge **170B** of superior component **160** to expand expandable intervertebral fusion implant **110** and lock it at a set height, as will be discussed in greater detail below. In some embodiments, teeth **144B** are stairs arranged on angled surface **143B**, with each step of the stairs including a tread that is parallel to directions **D3** and **D4** and a riser that is arranged at an angle relative to directions **D3** and **D4**. The arrangement of teeth **144B** as stairs allows expandable intervertebral fusion implant **110** to expand (i.e., by way of the engagement of the angled risers) and to at least partially lock or maintain at a certain height (i.e., by way of the engagement of the horizontal treads). The arrangement of the teeth **144B** as stairs also allows expandable intervertebral fusion implant **110** to collapse. In some embodiments, teeth **144B** are corrugations (i.e., ridges or grooves) arranged on angled surface **143B**. Wedge **140B** further comprises hole **146B** and locking member **147B** (see FIG. **9A**). As shown, locking member **147B** is a set screw which engages threaded hole **146B** in order to fixedly secure wedge **140B** to rail **132**, as will be discussed in greater detail below with respect to FIG. **10**. It should be appreciated that any means suitable for fixedly securing wedge **140B** to plate **124** may be used (e.g., a clamp, crimping the wedge about the rail to fixedly secure it thereto, adhesives, bolts, rivets, welding, soldering, etc.), and that the present disclosure should not be limited to just the use of a set screw. Wedge **140B** may further comprise hole **148B** for securing inferior component **120** to an adjacent vertebra with, for example, a bone screw. Hole **148B** is arranged at an angle relative to plate **124**, for example, generally in direction **D6**, and does not interfere with groove **142B** or rail **132**.

Wedge **150B** comprises groove **152B** and teeth **154B** arranged on angled surface **153B**. In the embodiment shown in FIGS. 7-12, wedge **150B** decreases in height in direction **D3** (i.e., surface **153A** slopes downward in direction **D4**). Groove **152B** is operatively arranged to engage rail **132**, as will be discussed in greater detail below with respect to FIG. **10**. Wedge **150B** is arranged to displace relative to plate **124** in direction **D3** and direction **D4**. Teeth **154B** are operatively arranged to engage teeth **184B** of wedge **180B** of superior component **160** to expand expandable intervertebral fusion implant **110** and lock it at a set height, as will be discussed in greater detail below. In some embodiments, teeth **154B** are stairs arranged on angled surface **153B**, with each step of the stairs including a tread that is parallel to directions **D3** and **D4** and a riser that is arranged at an angle relative to directions **D3** and **D4**. The arrangement of teeth **154B** as stairs allows expandable intervertebral fusion implant **110** to expand (i.e., by way of the engagement of the angled risers) and to at least partially lock or maintain at a certain height (i.e., by way of the engagement of the horizontal treads). The arrangement of the teeth **154B** as stairs also allows expandable intervertebral fusion implant **110** to collapse. In some embodiments, teeth **154B** are corrugations (i.e., ridges or grooves) arranged on angled surface **153B**. Wedge **150B** further comprises hole **156B** and locking member **157B** (see FIG. **9A**). As shown, locking member **157B** is a set screw which engages threaded hole **156B** in order to fixedly secure wedge **150B** to rail **132**, as will be discussed in greater detail

below with respect to FIG. **10**. It should be appreciated that any means suitable for fixedly securing wedge **150B** to plate **124** may be used (e.g., a clamp, crimping the wedge about the rail to fixedly secure it thereto, adhesives, bolts, rivets, welding, soldering, etc.), and that the present disclosure should not be limited to just the use of a set screw. Wedge **150B** may further comprise hole **158B** for securing inferior component **120** to an adjacent vertebra with, for example, a bone screw. Hole **158B** is arranged at an angle relative to plate **124**, for example, generally in direction **D6**, and does not interfere with groove **152B** or rail **132**.

Cross-members **126** and **128** connect plate **124** to plate **122**. In some embodiments, cross-members **126** and **128** are telescoping cross-members and allow for expandable intervertebral fusion implant **110** to be expanded and collapsed. For example, cross-members may comprise an inner rod displaceable (or slidable) within an outer rod. Plate **124** may be displaced relative to plate **122** in direction **D1** to expand expandable intervertebral fusion implant **110**, specifically inferior component **120**, and direction **D2** to collapse expandable intervertebral fusion implant **110**, specifically inferior component **120**. Cross-members **126** and **128** are fixed to respective ends, or proximate ends, of plates **122** and **124**. It should be appreciated that cross-members **126** and **128** do not have to be fixed at the ends of plates **122** and **124**, but rather can be fixed axially inward from the ends of plates **122** and **124**. In some embodiments, inferior component **120** comprises one cross-member that connects plates **122** and **124**. In some embodiments, inferior component **120** does not comprise any cross-members. In some embodiments, inferior component **120** comprises one or more cross-members connecting plates **122** and **124**, for example, three cross-members. It should be appreciated that although the drawings depict cross-members **126** and **128** having a circular cross-sectional geometry, any geometry suitable for expandably or displaceably connecting plates **122** and **124** may be used, for example, square, rectangular, triangular, ellipsoidal, etc. In some embodiments, cross-members **126** and **128** may be threaded (or locking) telescoping cross-members, similar or equivalent to cross-members **166** and **168** discussed in greater detail below. Additionally, it should be appreciated that in some embodiments, cross-members **126** and **128** are not telescoping and connect plate **124** to plate **122** at a set distance.

Superior component **160** comprises component **162**, component **164**, cross-member **166**, cross-member **168**, wedges **170A-B**, and wedges **180A-B**. In some embodiments, superior component **160** comprises only component **162**, wedge **170A**, and wedge **180A**.

Wedges **170A** and **180A** are connected to component **122**. Wedge **170A** comprises channel **172A** and teeth **174A** arranged on angled surface **173A**. In the embodiment shown in FIGS. 9-12, wedge **170A** decreases in height in direction **D4** (i.e., surface **173A** slopes downward in direction **D4**). Channel **172A** is operatively arranged to engage rail **130** in a fully collapsed position, as is shown in FIG. **7**. Channel **172A** allows superior component **160** to fully collapse with respect to inferior component **120** (i.e., such that wedges **170A** and **180A** and wedges **170B** and **180B** rest on plates **122** and **124**, respectively). Angled surface **173A** is operatively arranged to engage angled surface **143A** to expand superior component **160** with respect to inferior component **120**. Specifically, as wedge **140A** is displaced in direction **D3** relative to plate **122**, angled surface **143A** engages angled surface **173A** to displace superior component **160** in direction **D5** relative to inferior component **120**. Teeth **174A** are operatively arranged to engage teeth **144A** to lock

superior component 160 at a distance relative to inferior component 120. Specifically, teeth 174A engage teeth 144A to allow wedge 140A to displace in direction D3 relative to plate 122, and at the same time, if required, allow wedge 140A to displace in direction D4 relative to plate 122. Such arrangement allows expandable intervertebral fusion implant 110 to expand and collapse in a controlled fashion. In some embodiments, teeth 174A are stairs arranged on angled surface 173A, with each step of the stairs including a tread that is parallel to directions D3 and D4 and a riser that is arranged at an angle relative to directions D3 and D4. The arrangement of teeth 174A as stairs allows expandable intervertebral fusion implant 110 to expand (i.e., by way of the engagement of the angled risers) and to at least partially lock or maintain at a certain height (i.e., by way of the engagement of the horizontal treads). The arrangement of the teeth 174A as stairs also allows expandable intervertebral fusion implant 110 to collapse. In some embodiments, teeth 174A are corrugations (i.e., ridges or grooves) arranged on angled surface 173A. Wedge 170A may further comprise hole 176A for securing superior component 160 to an adjacent vertebra with, for example, a bone screw. Hole 176A is arranged at an angle relative to plate 122, for example, generally in direction D5.

Wedge 180A comprises channel 182A and teeth 184A arranged on angled surface 183A. In the embodiment shown in FIGS. 9-12, wedge 180A decreases in height in direction D3 (i.e., surface 183A slopes downward in direction D3). Channel 182A is operatively arranged to engage rail 130 in a fully collapsed position, as is shown in FIG. 7. Channel 182A allows superior component 160 to fully collapse with respect to inferior component 120 (i.e., such that wedges 170A and 180A and wedges 170B and 180B rest on plates 122 and 124, respectively). Angled surface 183A is operatively arranged to engage angled surface 153A to expand superior component 160 with respect to inferior component 120. Specifically, as wedge 150A is displaced in direction D4 relative to plate 122, angled surface 153A engages angled surface 183A to displace superior component 160 in direction D5 relative to inferior component 120. Teeth 184A are operatively arranged to engage teeth 154A to lock superior component 160 at a distance relative to inferior component 120. Specifically, teeth 184A engage teeth 154A to allow wedge 150A to displace in direction D4 relative to plate 122, and at the same time, if required, allow wedge 150A to displace in direction D3 relative to plate 122. Such arrangement allows expandable intervertebral fusion implant 110 to expand and collapse in a controlled fashion. In some embodiments, teeth 184A are stairs arranged on angled surface 183A, with each step of the stairs including a tread that is parallel to directions D3 and D4 and a riser that is arranged at an angle relative to directions D3 and D4. The arrangement of teeth 184A as stairs allows expandable intervertebral fusion implant 110 to expand (i.e., by way of the engagement of the angled risers) and to at least partially lock or maintain at a certain height (i.e., by way of the engagement of the horizontal treads). The arrangement of the teeth 184A as stairs also allows expandable intervertebral fusion implant 110 to collapse. In some embodiments, teeth 184A are corrugations (i.e., ridges or grooves) arranged on angled surface 183A. Wedge 180A may further comprise hole 186A for securing superior component 160 to an adjacent vertebra with, for example, a bone screw. Hole 186A is arranged at an angle relative to plate 122, for example, generally in direction D5.

Wedge 170B comprises channel 172B and teeth 174B arranged on angled surface 173B. In the embodiment shown

in FIGS. 7-12, wedge 170B decreases in height in direction D3 (i.e., surface 173B slopes downward in direction D3). Channel 172B is operatively arranged to engage rail 132 in a fully collapsed position, as is shown in FIG. 7. Channel 172B allows superior component 160 to fully collapse with respect to inferior component 120 (i.e., such that wedges 170A and 180A and wedges 170B and 180B rest on plates 122 and 124, respectively). Angled surface 173B is operatively arranged to engage angled surface 143B to expand superior component 160 with respect to inferior component 120. Specifically, as wedge 140B is displaced in direction D4 relative to plate 124, angled surface 143B engages angled surface 173B to displace superior component 160 in direction D5 relative to inferior component 120. Teeth 174B are operatively arranged to engage teeth 144B to lock superior component 160 at a distance relative to inferior component 120. Specifically, teeth 174B engage teeth 144B to allow wedge 140B to displace in direction D4 relative to plate 122, and at the same time, if required, allow wedge 140B to displace in direction D3 relative to plate 124. Such arrangement allows expandable intervertebral fusion implant 110 to expand and collapse in a controlled fashion. In some embodiments, teeth 174B are stairs arranged on angled surface 173B, with each step of the stairs including a tread that is parallel to directions D3 and D4 and a riser that is arranged at an angle relative to directions D3 and D4. The arrangement of teeth 174B as stairs allows expandable intervertebral fusion implant 110 to expand (i.e., by way of the engagement of the angled risers) and to at least partially lock or maintain at a certain height (i.e., by way of the engagement of the horizontal treads). The arrangement of the teeth 174B as stairs also allows expandable intervertebral fusion implant 110 to collapse. In some embodiments, teeth 174B are corrugations (i.e., ridges or grooves) arranged on angled surface 173B. Wedge 170B may further comprise hole 176B for securing superior component 160 to an adjacent vertebra with, for example, a bone screw. Hole 176B is arranged at an angle relative to plate 124, for example, generally in direction D5.

Wedge 180B comprises channel 182B and teeth 184B arranged on angled surface 183B. In the embodiment shown in FIGS. 7-12, wedge 180B decreases in height in direction D4 (i.e., surface 183B slopes downward in direction D4). Channel 182B is operatively arranged to engage rail 132 in a fully collapsed position, as is shown in FIG. 7. Channel 182B allows superior component 160 to fully collapse with respect to inferior component 120 (i.e., such that wedges 170A and 180A and wedges 170B and 180B rest on plates 122 and 124, respectively). Angled surface 183B is operatively arranged to engage angled surface 153B to expand superior component 160 with respect to inferior component 120. Specifically, as wedge 150B is displaced in direction D3 relative to plate 124, angled surface 153B engages angled surface 183B to displace superior component 160 in direction D5 relative to inferior component 120. Teeth 184B are operatively arranged to engage teeth 154B to lock superior component 160 at a distance relative to inferior component 120. Specifically, teeth 184B engage teeth 154B to allow wedge 150B to displace in direction D3 relative to plate 124, and at the same time, if required, allow wedge 150B from displacing in direction D4 relative to plate 124. Such arrangement allows expandable intervertebral fusion implant 110 to expand and collapse in a controlled fashion. In some embodiments, teeth 184B are stairs arranged on angled surface 183B, with each step of the stairs including a tread that is parallel to directions D3 and D4 and a riser that is arranged at an angle relative to directions D3 and D4. The

arrangement of teeth **184B** as stairs allows expandable intervertebral fusion implant **110** to expand (i.e., by way of the engagement of the angled risers) and to at least partially lock or maintain at a certain height (i.e., by way of the engagement of the horizontal treads). The arrangement of the teeth **184B** as stairs also allows expandable intervertebral fusion implant **110** to collapse. In some embodiments, teeth **184B** are corrugations (i.e., ridges or grooves) arranged on angled surface **183B**. Wedge **180B** may further comprise hole **186B** for securing superior component **160** to an adjacent vertebra with, for example, a bone screw. Hole **186B** is arranged at an angle relative to plate **124**, for example, generally in direction **D5**.

Cross-members **166** and **168** connect component **164** to component **162**. In some embodiments, cross-members **166** and **168** are telescoping cross-members and allow for expandable intervertebral fusion implant **110** to be expanded and collapsed. For example, cross-members may comprise an inner rod displaceable (or slidable) within an outer rod. Component **164** may be displaced relative to component **162** in direction **D1** to expand expandable intervertebral fusion implant **110**, specifically superior component **160**, and direction **D2** to collapse expandable intervertebral fusion implant **110**, specifically superior component **160**. Cross-members **166** and **168** are fixed to respective ends, or proximate ends, of components **162** and **164**. It should be appreciated that cross-members **166** and **168** do not have to be fixed at the ends of components **162** and **164**, but rather can be fixed axially inward from the ends of components **162** and **164**. In some embodiments, superior component **160** comprises one cross-member that connects components **162** and **164**. In some embodiments, superior component **160** does not comprise any cross-members. In some embodiments, superior component **160** comprises one or more cross-members connecting components **162** and **164**, for example, three cross-members. In some embodiments, cross-members **166** and **168** are threadably engaged, as will be discussed in greater detail below with respect to FIG. **11**. It should be appreciated that although the drawings depict cross-members **166** and **168** having a circular cross-sectional geometry, any geometry suitable for expandably or displaceably connecting components **162** and **164** may be used, for example, square, rectangular, triangular, ellipsoidal, etc. Additionally, it should be appreciated that in some embodiments, cross-members **166** and **168** are not telescoping and connect component **164** to component **162** at a set distance.

FIG. **9B** is a side elevational view of expandable intervertebral fusion implant **110** in a fully collapsed state as shown in FIG. **7**. Cross-members **168** and **128**, along with cross-members **126** and **166** (not shown in FIG. **9B**) are telescoping such that expandable intervertebral fusion implant **110** is expandable in the anterior-posterior directions (i.e., directions **D1** and **D2**). Cross-member **168** comprises inner rod **168A** arranged to threadably engage outer rod **168B**. Cross-member **168** may comprise threading operatively arranged to expand and contract expandable intervertebral fusion implant **110**, and lock inner rod **168A** and outer rod **168B** at a set length. The threadable engagement of inner rod **168A** and outer rod **168B** will be discussed in greater detail below. Cross-member **128** comprises inner rod **128A** arranged to slidably engage outer rod **128B**. Cross-member **128** may further comprise threading or a plurality of pins arranged to lock inner rod **128A** and outer rod **128B** at a set length. Cross-members **126** and **166** are arranged substantially similar to cross-members **128** and **168**. For example, cross-member **126** comprises inner rod **126A** arranged to slidably engage outer rod **126B**, and may further comprise threading

or a plurality of pins arranged to lock inner rod **126A** and outer rod **126B** at a set length. Cross-member **166** comprises inner rod **166A** arranged to slidably engage outer rod **166B**, and may further comprise threading or a plurality of pins arranged to lock inner rod **166A** and outer rod **166B** at a set length (as is discussed in greater detail with respect to FIG. **11** below).

Also shown in FIG. **9B** are rails **130** and **132** arranged on plates **122** and **124**, respectively. Grooves **142A** and **152B** of wedges **140A** and **150B** engage rails **130** and **132**, respectively, and grooves **152A** and **142B** of wedges **150A** and **140B** engage rails **130** and **132**, respectively (not shown in FIG. **10B**). Furthermore, in the fully collapsed position, channels **172A** and **182B** of wedges **170A** and **180B** engage rails **130** and **132**, respectively, and channels **182A** and **172B** of wedges **180A** and **170B** engage rails **130** and **132**, respectively (not shown).

FIG. **10** is a cross-sectional view of a tongue and groove connection taken generally along line **10-10** in FIG. **7**. Groove **152A** of wedge **150A** generally comprises channel **90**, opening **92**, and sides **94** and **96**. Rail **130** of plate **122** comprises runner **80**. Groove **152A** is arranged to enclose runner **80**, such that wedge **150A** and plate **122** are slidably connected. It should be appreciated that wedge **140A** and wedges **140B** and **150B** are arranged substantially similar to wedge **150A** with respect to engagement with respective rails **130** and **132**. Specifically, groove **142A** of wedge **140A** slidably engages runner **80** of rail **130**. Similarly, grooves **142B** and **152B** of wedges **140B** and **150B** slidably engage the runner of rail **132**.

Also shown in FIG. **10** is locking member or screw **157A** arranged in hole **156A** and engaged with rail **130**. FIG. **10** shows wedge **150A** in a locked position relative to rail **130**. Specifically, screw **157A** has been tightened within hole **156A** (i.e., screw **157A** is displaced in direction **D1**) such that screw **157A** abuts against runner **80**. The frictional force between screw **157A** and runner **80** prevents displacement of wedge **150A** with respect to plate **122**. When screw **157A** is loosened within hole **156A** (i.e., screw **157A** is displaced in direction **D2**) such that screw **157A** no longer abuts against runner **80**, wedge **150A** is again displaceable relative to plate **122**. It should be appreciated that locking member or screw **147A** and locking members or screws **147B** and **157B** are arranged to engage rails **130** and **132**, respectively, in a substantially similar fashion to that of locking member or screw **157** as described above. In some embodiments, plate **122** is expandable and comprises an extension which engages hole **123B**, which will be discussed in greater detail with respect to FIG. **12**.

FIG. **11** is a cross-sectional view of cross-member **166** taken generally along line **11-11** in FIG. **8**. As previously discussed, cross-member **166** comprises inner rod **166A** arranged to displaceably (e.g., threadably) engage outer rod **166B**. In the embodiment shown, inner rod **166A** comprises outer threading **102** and outer rod **166B** comprises inner threading **104**. Outer threading **102** engages inner threading **104** to expand and contract expandable intervertebral fusion implant **110**. For example, as inner rod **166A** is rotated in a first circumferential direction, outer rod **166B** displaces relative to inner rod **166A** in direction **D1**, thereby expanding expandable intervertebral fusion implant **110**. As inner rod **166A** is rotated in a second circumferential direction, outer rod **166B** displaces relative to inner rod **166A** in direction **D2**, thereby contracting or collapsing expandable intervertebral fusion implant **110**. Similarly, as outer rod **166B** is rotated in a first circumferential direction, inner rod **166A** displaces relative to outer rod **166B** in direction **D2**,

thereby expanding expandable intervertebral fusion implant 110. As outer rod 166B is rotated in a second circumferential direction, inner rod 166A displaces relative to outer rod 166B in direction D1, thereby contracting or collapsing expandable intervertebral fusion implant 110. As such, in some embodiments, one of inner rod 166A and outer rod 166B is fixedly secured to superior component 160, and the other is rotatably secured to superior component 160 (i.e., inner rod 166A must be able to be rotated relative to the outer rod 166B or vice versa). In some embodiments, at least one of inner rod 166A and outer rod 166B is rotatably secured to superior component 160 or inferior component 120. This similar locking mechanism (i.e., threading) may be used on cross-members 126, 128, and 168. It should be appreciated that telescoping members are known in the art and that any suitable telescoping design may be used. In an example embodiment, one or more cross-members have a locking mechanism. In an example embodiment, no cross-members have a locking mechanism.

FIG. 12 is a perspective view of plate 122, in an expanded state. It should be appreciated that plate 124, and plates 222 and 224 (discussed below), may comprise a substantially similar or the same design as plate 122 as described in FIG. 12. In the embodiment shown, plate 122 comprises section 122A, section 122B, and rail 130. Section 122B is operatively arranged to displace relative to section 122B in direction D4 to expand plate 122, and in direction D3 to collapse plate 122. In some embodiments, section 122A comprises extension 123A which slidably engages hole 123B of section 122B. One of sections 122A and 122B may further comprise a locking mechanism. In the embodiment shown, section 122B comprises hole 106 and screw 108 (e.g., a set screw), which is operatively arranged to engage extension 123A to lock section 122B at a set distance from section 122A. It should be appreciated that plate 122 may use any known expansion mechanism or means for expansion. It should further be appreciated that plate 122 may use any known locking mechanism to lock section 122B at a set distance from section 122A.

In some embodiments, components 162, 164, 262, and 264 comprise a similar design to plate 122, namely, that each of components 162, 164, 262, and 264 are laterally expandable. For example, each of components 162, 164, 262, and 264 may comprise a first section including an extension and a second section including a hole, the extension is operatively arranged to slidably engage the hole, and the two sections are locked via a set screw (see FIG. 12).

FIG. 13 is a front perspective view of expandable intervertebral fusion implant 210, in a fully collapsed state. FIG. 14 is a front perspective view of expandable intervertebral fusion implant 210, in an expanded state. Expandable intervertebral fusion implant 210 generally comprises inferior component 220 and superior component 260. The following description should be read in view of FIGS. 13-14.

Inferior component 220 comprises plate 222, plate 224, cross-member 226, cross-member 228, wedges 240A-B, and wedges 250A-B. In some embodiments, inferior component 220 comprises only plate 222, wedge 240A, and wedge 250A.

Wedges 240A and 250A are slidably engaged with plate 222. In some embodiments, and as shown in the figures, plate 222 comprises rail 230, and wedges 240A and 250A are slidably connected to rail 230. In some embodiments, plate 222 is expandable, as was discussed above with respect to FIG. 12.

Wedge 240A comprises groove 242A and teeth 244A arranged on angled surface 243A. In the embodiment shown in FIGS. 13-14, wedge 240A decreases in height in direction D4 (i.e., surface 243A slopes downward in direction D4).

Groove 242A is operatively arranged to engage rail 230. Wedge 240A is arranged to displace relative to plate 222 in direction D3 and direction D4. Teeth 244A are operatively arranged to engage teeth 274A of wedge 270A of superior component 260 to expand expandable intervertebral fusion implant 210 and lock it at a set height, as will be discussed in greater detail below. Wedge 240A further comprises hole 246A and locking member 247A. As shown, locking member 247A is a set screw which engages threaded hole 246A in order to fixedly secure wedge 240A to rail 230. It should be appreciated that any means suitable for fixedly securing wedge 240A to plate 222 may be used (e.g., a clamp, crimping the wedge about the rail to fixedly secure it thereto, adhesives, bolts, rivets, welding, soldering, etc.), and that the present disclosure should not be limited to just the use of a set screw.

Wedge 250A comprises groove 252A and teeth 254A arranged on angled surface 253A. In the embodiment shown in FIGS. 13-14, wedge 250A decreases in height in direction D3 (i.e., surface 253A slopes downward in direction D3).

Groove 252A is operatively arranged to engage rail 230. Wedge 250A is arranged to displace relative to plate 222 in direction D3 and direction D4. Teeth 254A are operatively arranged to engage teeth 284A of wedge 280A of superior component 260 to expand expandable intervertebral fusion implant 210 and lock it at a set height, as will be discussed in greater detail below. Wedge 245A further comprises hole 256A and locking member 257A. As shown, locking member 257A is a set screw which engages threaded hole 256A in order to fixedly secure wedge 250A to rail 230. It should be appreciated that any means suitable for fixedly securing wedge 250A to plate 222 may be used (e.g., a clamp, crimping the wedge about the rail to fixedly secure it thereto, adhesives, bolts, rivets, welding, soldering, etc.), and that the present disclosure should not be limited to just the use of a set screw. Plate 222 may further comprise hole 248A for securing inferior component 220 to an adjacent vertebra with, for example, a bone screw. Hole 248A is arranged at an angle relative to plate 222, for example, generally in direction D6, and does not interfere with rail 230.

Wedges 240B and 250B are slidably engaged with plate 224. In some embodiments, and as shown in the figures, plate 224 comprises rail 232, and wedges 240B and 250B are slidably connected to rail 232. In some embodiments, plate 224 is expandable, as was discussed above with respect to FIG. 12.

Wedge 240B comprises groove 242B and teeth 244B arranged on angled surface 243B. In the embodiment shown in FIGS. 13-14, wedge 240B decreases in height in direction D3 (i.e., surface 243B slopes downward in direction D3).

Groove 242B is operatively arranged to engage rail 232. Wedge 240B is arranged to displace relative to plate 224 in direction D3 and direction D4. Teeth 244B are operatively arranged to engage teeth 274B of wedge 270B of superior component 260 to expand expandable intervertebral fusion implant 210 and lock it at a set height, as will be discussed in greater detail below. Wedge 240B further comprises hole 246B and locking member 247B (not shown). Locking member 247B is a set screw which engages threaded hole 246B in order to fixedly secure wedge 240B to rail 230. It should be appreciated that any means suitable for fixedly securing wedge 240B to plate 222 may be used (e.g., a clamp, crimping the wedge about the rail to fixedly secure

it thereto, adhesives, bolts, rivets, welding, soldering, etc.), and that the present disclosure should not be limited to just the use of a set screw.

Wedge **250B** comprises groove **252B** and teeth **254B** arranged on angled surface **253B**. In the embodiment shown in FIGS. **13-14**, wedge **250B** decreases in height in direction **D4** (i.e., surface **253B** slopes downward in direction **D4**). Groove **252B** is operatively arranged to engage rail **232**. Wedge **250B** is arranged to displace relative to plate **222** in direction **D3** and direction **D4**. Teeth **254B** are operatively arranged to engage teeth **284B** of wedge **280B** of superior component **260** to expand expandable intervertebral fusion implant **210** and lock it at a set height, as will be discussed in greater detail below. Wedge **245B** further comprises hole **256B** and locking member **257B** (not shown). Locking member **257B** is a set screw which engages threaded hole **256B** in order to fixedly secure wedge **250B** to rail **232**. It should be appreciated that any means suitable for fixedly securing wedge **250B** to plate **222** may be used (e.g., a clamp, crimping the wedge about the rail to fixedly secure it thereto, adhesives, bolts, rivets, welding, soldering, etc.), and that the present disclosure should not be limited to just the use of a set screw. Plate **222** may further comprise hole **248B** for securing inferior component **220** to an adjacent vertebra with, for example, a bone screw. Hole **248B** is arranged at an angle relative to plate **222**, for example, generally in direction **D6**, and does not interfere with rail **232**.

Cross-members **226** and **228** connect plate **224** to plate **222**. In some embodiments, cross-members **226** and **228** are telescoping cross-members and allow for expandable intervertebral fusion implant **210** to be expanded and collapsed. For example, cross-members may comprise an inner rod slidable within an outer rod. Plate **224** may be displaced relative to plate **222** in direction **D1** to expand expandable intervertebral fusion implant **210**, specifically inferior component **220**, and direction **D2** to collapse expandable intervertebral fusion implant **210**, specifically inferior component **220**. Cross-members **226** and **228** are fixed to respective ends, or proximate ends, of plates **222** and **224**. It should be appreciated that cross-members **226** and **228** do not have to be fixed at the ends of plates **222** and **224**, but rather can be fixed axially inward from the ends of plates **222** and **224**. In some embodiments, inferior component **220** comprises one cross-member that connects plates **222** and **224**. In some embodiments, inferior component **220** does not comprise any cross-members. In some embodiments, inferior component **220** comprises one or more cross-members connecting plates **222** and **224**, for example, three cross-members. It should be appreciated that although the drawings depict cross-members **226** and **228** having a circular cross-sectional geometry, any geometry suitable for expandably or displaceably connecting plates **222** and **224** may be used, for example, square, rectangular, triangular, ellipsoidal, etc. In some embodiments, cross-members **226** and **228** may be locking telescoping cross-members, similar or equivalent to cross-members **266** and **268** discussed in greater detail below. Additionally, it should be appreciated that in some embodiments, cross-members **226** and **228** are not telescoping and connect plate **224** to plate **222** at a set distance. Cross-members **226** and **228** may include an inner rod and an outer rod, and may also include threading (or locking pins) as discussed above with respect to FIG. **11**.

Superior component **260** comprises component **262**, component **264**, cross-member **266**, cross-member **268**, wedges

270A-B, and wedges **280A-B**. In some embodiments, superior component **260** comprises only component **262**, wedge **270A**, and wedge **280A**.

Wedges **270A** and **280A** are connected to component **222**. Wedge **270A** comprises channel **272A** and teeth **274A** arranged on angled surface **273A**. In the embodiment shown in FIGS. **13-14**, wedge **270A** decreases in height in direction **D3** (i.e., surface **273A** slopes downward in direction **D3**). Channel **272A** is operatively arranged to engage rail **230** in a fully collapsed position, as is shown in FIG. **13**. Channel **272A** allows superior component **260** to fully collapse with respect to inferior component **220** (i.e., such that wedges **270A** and **280A** and wedges **270B** and **280B** rest on plates **222** and **224**, respectively). Angled surface **273A** is operatively arranged to engage angled surface **243A** to expand superior component **260** with respect to inferior component **220**. Specifically, as wedge **240A** is displaced in direction **D4** relative to plate **222**, angled surface **243A** engages angled surface **273A** to displace superior component **260** in direction **D5** relative to inferior component **220**. Teeth **274A** are operatively arranged to engage teeth **244A** to lock superior component **260** at a distance relative to inferior component **220**. Specifically, teeth **274A** engage teeth **244A** to allow wedge **240A** to displace in direction **D4** relative to plate **222**, and at the same time, if required, allow wedge **240A** to displace in direction **D3** relative to plate **222**. Such arrangement allows expandable intervertebral fusion implant **210** to expand and collapse in a controlled fashion.

Wedge **280A** comprises channel **282A** and teeth **284A** arranged on angled surface **283A**. In the embodiment shown in FIGS. **13-14**, wedge **280A** decreases in height in direction **D4** (i.e., surface **283A** slopes downward in direction **D4**). Channel **282A** is operatively arranged to engage rail **230** in a fully collapsed position, as is shown in FIG. **13**. Channel **282A** allows superior component **260** to fully collapse with respect to inferior component **220** (i.e., such that wedges **270A** and **280A** and wedges **270B** and **280B** rest on plates **222** and **224**, respectively). Angled surface **283A** is operatively arranged to engage angled surface **253A** to expand superior component **260** with respect to inferior component **220**. Specifically, as wedge **250A** is displaced in direction **D3** relative to plate **222**, angled surface **253A** engages angled surface **283A** to displace superior component **260** in direction **D5** relative to inferior component **220**. Teeth **284A** are operatively arranged to engage teeth **254A** to lock superior component **260** at a distance relative to inferior component **220**. Specifically, teeth **284A** engage teeth **254A** to allow wedge **250A** to displace in direction **D3** relative to plate **222**, and at the same time, if required, allow wedge **250A** to displace in direction **D4** relative to plate **222**. Such arrangement allows expandable intervertebral fusion implant **210** to expand and collapse in a controlled fashion. Component **262** may further comprise hole **276A** for securing superior component **260** to an adjacent vertebra with, for example, a bone screw. Hole **276A** is arranged at an angle relative to plate **222**, for example, generally in direction **D5**.

Wedges **270B** and **280B** are connected to component **224**. Wedge **270B** comprises channel **272B** and teeth **274B** arranged on angled surface **273B**. In the embodiment shown in FIGS. **13-14**, wedge **270B** decreases in height in direction **D4** (i.e., surface **273B** slopes downward in direction **D4**). Channel **272B** is operatively arranged to engage rail **232** in a fully collapsed position, as is shown in FIG. **13**. Channel **272B** allows superior component **260** to fully collapse with respect to inferior component **220** (i.e., such that wedges **270A** and **280A** and wedges **270B** and **280B** rest on plates **222** and **224**, respectively). Angled surface **273B** is opera-

tively arranged to engage angled surface 243B to expand superior component 260 with respect to inferior component 220. Specifically, as wedge 240B is displaced in direction D3 relative to plate 222, angled surface 243B engages angled surface 273B to displace superior component 260 in direction D5 relative to inferior component 220. Teeth 274B are operatively arranged to engage teeth 244B to lock superior component 260 at a distance relative to inferior component 220. Specifically, teeth 274B engage teeth 244B to allow wedge 240B to displace in direction D3 relative to plate 222, and at the same time, if required, allow wedge 240B to displace in direction D4 relative to plate 222. Such arrangement allows expandable intervertebral fusion implant 210 to expand and collapse in a controlled fashion.

Wedge 280B comprises channel 282B and teeth 284B arranged on angled surface 283B. In the embodiment shown in FIGS. 13-14, wedge 280B decreases in height in direction D3 (i.e., surface 283B slopes downward in direction D3). Channel 282B is operatively arranged to engage rail 232 in a fully collapsed position, as is shown in FIG. 13. Channel 282B allows superior component 260 to fully collapse with respect to inferior component 220 (i.e., such that wedges 270A and 280A and wedges 270B and 280B rest on plates 222 and 224, respectively). Angled surface 283B is operatively arranged to engage angled surface 253B to expand superior component 260 with respect to inferior component 220. Specifically, as wedge 250B is displaced in direction D4 relative to plate 224, angled surface 253B engages angled surface 283B to displace superior component 260 in direction D5 relative to inferior component 220. Teeth 284B are operatively arranged to engage teeth 254B to lock superior component 260 at a distance relative to inferior component 220. Specifically, teeth 284B engage teeth 254B to allow wedge 250B to displace in direction D4 relative to plate 222, and at the same time, if required, allow wedge 250B to displace in direction D3 relative to plate 222. Such arrangement allows expandable intervertebral fusion implant 210 to expand and collapse in a controlled fashion. Component 262 may further comprise hole 276A for securing superior component 260 to an adjacent vertebra with, for example, a bone screw. Hole 276A is arranged at an angle relative to plate 222, for example, generally in direction D5.

Cross-members 266 and 268 connect component 264 to component 262. In some embodiments, cross-members 266 and 268 are telescoping cross-members and allow for expandable intervertebral fusion implant 210 to be expanded and collapsed. For example, cross-members may comprise an inner rod displaceable (or slidable) within an outer rod. Component 264 may be displaced relative to component 262 in direction D1 to expand expandable intervertebral fusion implant 210, specifically superior component 260, and direction D2 to collapse expandable intervertebral fusion implant 210, specifically superior component 260. Cross-members 266 and 268 are fixed to respective ends, or proximate ends, of components 262 and 264. It should be appreciated that cross-members 266 and 268 do not have to be fixed at the ends of components 262 and 264, but rather can be fixed axially inward from the ends of components 262 and 264. In some embodiments, superior component 260 comprises one cross-member that connects components 262 and 264. In some embodiments, superior component 260 does not comprise any cross-members. In some embodiments, superior component 260 comprises one or more cross-members connecting components 262 and 264, for example, three cross-members. It should be appreciated that although the drawings depict cross-members 266 and 268 having a circular cross-sectional geometry, any geometry suitable for expand-

ably or displaceably connecting components 262 and 264 may be used, for example, square, rectangular, triangular, ellipsoidal, etc. Additionally, it should be appreciated that in some embodiments, cross-members 266 and 268 are not telescoping and connect component 264 to component 262 at a set distance. In some embodiments, cross-members 266 and 268 may include an inner rod and an outer rod, and may also include locking pins. In some embodiments, cross-members 266 and 268 comprise an inner rod threadably engaged with an outer rod, as discussed above with respect to FIG. 11.

FIG. 15 is an anterior perspective view of a spinal column including expandable intervertebral fusion implant 110. Expandable intervertebral implant 110 is inserted into the spinal column between, for example, the L3 and L4 vertebrae, or where disc D_{L3-L4} should be. Expandable intervertebral implant 110 is then vertically expanded until the desired height is reached. Expandable intervertebral implant 110 may be expanded in the anterior-posterior directions (i.e., directions D1 and D2) prior to insertion, or after insertion, as previously discussed (i.e., along telescoping cross-members). Expandable intervertebral implant 110 is then filled with fusion material and left in situ.

It will be appreciated that various aspects of the disclosure above and other features and functions, or alternatives thereof, may be desirably combined into many other different systems or applications. Various presently unforeseen or unanticipated alternatives, modifications, variations, or improvements therein may be subsequently made by those skilled in the art which are also intended to be encompassed by the following claims.

REFERENCE NUMERALS

10	Spinal column
12	Ligament
C1-C7	Cervical vertebrae
T1-T12	Thoracic vertebrae
L1-L5	Lumbar vertebrae
S	Sacrum
C	Coccyx
D_{L1-L2}	Disc
D_{L2-L3}	Disc
D_{L3-L4}	Disc
D_{L4-L5}	Disc
F	Facet
FJ	Facet joint
SP	Spinous process
TP	Transverse process
IF	Intervertebral foramen
NC	Neural canal
A	Annulus
N	Nucleus
DH	Disc space height
80	Runner
90	Channel
92	Opening
94	Side
96	Side
102	Threading
104	Threading
106	Hole
108	Screw
110	Expandable intervertebral fusion implant
120	Inferior component
122	Plate
122A	Section

122B Section
 123A Extension
 123B Hole
 124 Plate
 126 Cross-member
 126A Inner rod
 126B Outer rod
 128 Cross-member
 128A Inner rod
 128B Outer rod
 130 Rail
 132 Rail
 140A Wedge
 140B Wedge
 142A Groove
 142B Groove
 143A Surface
 143B Surface
 144A Teeth
 144B Teeth
 146A Hole
 146B Hole
 147A Locking member (screw)
 147B Locking member (screw)
 148A Hole
 148B Hole
 150A Wedge
 150B Wedge
 152A Groove
 152B Groove
 153A Surface
 153B Surface
 154A Teeth
 154B Teeth
 156A Hole
 156B Hole
 157A Locking member (screw)
 157B Locking member (screw)
 158A Hole
 158B Hole
 160 Superior component
 162 Component
 164 Component
 166 Cross-member
 166A Inner rod
 166B Outer rod
 168 Cross-member
 168A Inner rod
 168B Outer rod
 170A Wedge
 170B Wedge
 172A Channel
 172B Channel
 173A Surface
 173B Surface
 174A Teeth
 174B Teeth
 176A Hole
 176B Hole
 180A Wedge
 180B Wedge
 182A Channel
 182B Channel
 183A Surface
 183B Surface
 184A Teeth
 184B Teeth

186A Hole
 186B Hole
 210 Expandable intervertebral fusion implant
 220 Inferior component
 5 222 Plate
 224 Plate
 226 Cross-member
 226A Inner rod (not shown)
 226B Outer rod (not shown)
 10 228 Cross-member
 228A Inner rod (not shown)
 228B Outer rod (not shown)
 230 Rail
 232 Rail
 15 240A Wedge
 240B Wedge
 242A Groove
 242B Groove
 243A Surface
 20 243B Surface
 244A Teeth
 244B Teeth
 246A Hole
 246B Hole
 25 247A Screw
 247B Screw
 248A Hole
 248B Hole
 250A Wedge
 30 250B Wedge
 252A Groove
 252B Groove
 253A Surface
 253B Surface
 35 254A Teeth
 254B Teeth
 256A Hole
 256B Hole
 257A Screw
 40 257B Screw
 260 Superior component
 262 Component
 264 Component
 266 Cross-member
 45 266A Inner rod (not shown)
 266B Outer rod (not shown)
 268 Cross-member
 268A Inner rod (not shown)
 268B Outer rod (not shown)
 50 270A Wedge
 270B Wedge
 272A Channel
 272B Channel
 273A Surface
 55 273B Surface
 274A Teeth
 274B Teeth
 276A Hole
 276B Hole
 60 280A Wedge
 280B Wedge
 282A Channel
 282B Channel
 283A Surface
 65 283B Surface
 284A Teeth
 284B Teeth

D1 Direction
 D2 Direction
 D3 Direction
 D4 Direction
 D5 Direction
 D6 Direction

What is claimed is:

1. An expandable intervertebral fusion implant, comprising:

an inferior component, including:

a plate; and,

a first wedge slidably connected to the plate, the first wedge including a first surface comprising a first plurality of teeth; and,

a superior component including a second wedge, the second wedge including a second surface comprising a second plurality of teeth;

wherein:

the first surface is operatively arranged to engage the second surface to displace the superior component relative to the inferior component;

the second plurality of teeth are operatively arranged to engage the first plurality of teeth to maintain the expandable intervertebral fusion implant at a height and in a fully expanded position; and,

in a fully collapsed position of the expandable intervertebral fusion implant, the first wedge and the second wedge are arranged entirely between the plate and the superior component.

2. The expandable intervertebral fusion implant as recited in claim 1, wherein the first plurality of teeth include a first plurality of stairs and the second plurality of teeth include a second plurality of stairs.

3. The expandable intervertebral fusion implant as recited in claim 2, wherein:

each step in the first plurality of stairs includes a first tread arranged parallel to the plate and a first riser arranged at a first angle relative to the plate; and,

each step in the second plurality of stairs includes a second tread arranged parallel to the first tread and a second riser arranged at a second angle relative to the plate.

4. The expandable intervertebral fusion implant as recited in claim 3, wherein the second riser is arranged parallel to the first riser.

5. The expandable intervertebral fusion implant as recited in claim 1, wherein the first wedge is operatively arranged to be locked to the plate.

6. The expandable intervertebral fusion implant as recited in claim 5, wherein the first wedge further comprises a screw operatively arranged to lock the first wedge with respect to the plate.

7. The expandable intervertebral fusion implant as recited in claim 1, wherein the plate comprises a rail, the first wedge being slidably engaged with the rail.

8. The expandable intervertebral fusion implant as recited in claim 1, wherein:

the inferior component further comprises a third wedge having a third surface; and,

the superior component further comprises a fourth wedge having a fourth surface;

wherein the third surface is operatively arranged to engage the fourth surface to displace the superior component relative to the inferior component.

9. The expandable intervertebral fusion implant as recited in claim 8, wherein the third wedge is displaceable relative to the first wedge.

10. The expandable intervertebral fusion implant as recited in claim 8, wherein the fourth wedge is fixedly securable to the second wedge.

11. The expandable intervertebral fusion implant as recited in claim 8, wherein as the first wedge is displaced in a first direction relative to the plate, the superior component is displaced in a second direction relative to the inferior component.

12. The expandable intervertebral fusion implant as recited in claim 11, wherein as the third wedge is displaced in a third direction relative to the plate, the third direction being opposite the first direction, the superior component is displaced in the second direction relative to the inferior component.

13. The expandable intervertebral fusion implant as recited in claim 11, wherein the second direction is perpendicular to the first direction.

14. The expandable intervertebral fusion implant as recited in claim 1, wherein the plate is expandable.

15. The expandable intervertebral fusion implant as recited in claim 1, wherein the superior component is expandable.

16. An expandable intervertebral fusion implant, comprising:

an inferior component, including:

a first plate;

a first wedge slidably connected to the first plate, the first wedge having a first surface;

a second plate;

a second wedge slidably connected to the second plate, the second wedge having a second surface; and, at least one first cross-member connecting the first and second plates; and,

a superior component, including:

a first component including a third wedge, the third wedge having a third surface;

a second component including a fourth wedge, the fourth wedge having a fourth surface; and,

at least one second cross-member connecting the first and second components;

wherein:

the first and second surfaces are operatively arranged to engage the third and fourth surfaces, respectively, to displace the superior component relative to the inferior component; and,

in a fully collapsed position of the expandable intervertebral fusion implant, the first wedge and the third wedge are arranged entirely between the first plate and the first component.

17. The expandable intervertebral fusion implant as recited in claim 16, wherein at least one of the first surface and the second surface comprises a first plurality of teeth and at least one of the third surface and the fourth surface comprises a second plurality of teeth, the second plurality of teeth operatively arranged to engage the first plurality of teeth to maintain the expandable intervertebral fusion implant at a height.

18. The expandable intervertebral fusion implant as recited in claim 16, wherein at least one of the first wedge and the second wedge is operatively arranged to be locked to the first and/or second plates, respectively.

19. The expandable intervertebral fusion implant as recited in claim 16, wherein the first plate comprises a first rail, the first wedge being slidably engaged with the first rail.

20. The expandable intervertebral fusion implant as recited in claim 16, wherein:

the inferior component further comprises:

23

a fifth wedge including a fifth surface, the fifth wedge slidably engaged with the first plate; and, a sixth wedge including a sixth surface, the sixth wedge slidably engaged with the second plate; and, the superior component further comprises:
 a seventh wedge including a seventh surface, the seventh wedge connected to the first component; and, an eighth wedge including an eighth surface, the eighth wedge connected to the second component;
 wherein the fifth and sixth surfaces are operatively arranged to engage the seventh and eighth surfaces, respectively, to displace the superior component relative to the inferior component.

21. The expandable intervertebral fusion implant as recited in claim 20, wherein the first, second, fifth, and sixth wedges are displaceable relative to each other.

22. The expandable intervertebral fusion implant as recited in claim 20, wherein the third wedge is fixedly secured to the seventh wedge, and the fourth wedge is fixedly secured to the eighth wedge.

23. The expandable intervertebral fusion implant as recited in claim 20, wherein as the first wedge is displaced in a first direction relative to the first plate or the fifth wedge is displaced in a second direction, opposite the first direction, relative to the first plate, the superior component is displaced in a third direction relative to the inferior component.

24. The expandable intervertebral fusion implant as recited in claim 23, wherein as the second wedge is displaced in the first direction relative to the second plate or the sixth wedge is displaced in the second direction relative to the second plate, the superior component is displaced in the third direction.

24

25. The expandable intervertebral fusion implant as recited in claim 23, wherein the third direction is perpendicular to the first and second directions.

26. The expandable intervertebral fusion implant as recited in claim 16, wherein at least one of the first plate and the second plate is expandable.

27. The expandable intervertebral fusion implant as recited in claim 16, wherein at least one of the first and second cross-members are telescoping.

28. An expandable intervertebral fusion implant, comprising:

an inferior component, including:

a plate; and,

a first wedge slidably connected to the plate, the first wedge having a first surface; and,

a superior component including a second wedge, the second wedge having a second surface;

wherein:

the first wedge is operatively arranged to displace in a first direction from a middle of the plate to an end of the plate and the first surface is operatively arranged to engage the second surface to displace the superior component in a second direction away from the inferior component, the second direction being perpendicular to the first direction; and,

in a fully collapsed position of the expandable intervertebral fusion implant, the first wedge and the second wedge are arranged between the plate and the superior component.

* * * * *